

User Guide

GenPro 53e



Reference : EG_GenPro53e_1040_UG_003_UK

Revision : 003

Date : 05/07/2011

Document History

Révision	Modifications	Author	Date
000	CREATION	YST	27/10/10
001	Updated the location of the connector Micro Fit 16-pins female (Page 19)	YST	03/11/10
002	Change pin out of analogic input ANA1 and ANA2 Updating - the limit of use of the digital input du § 8.2.3.1 Opto-coupled Inputs - the non-guarantee of the battery § 9.3 Care and maintenance	YST	04/03/11
003	Updating - de la désignation EaseLoc_Vx - § 5.1.3.3 The application ERCO & GENER EasePro_Vx - § 5.3.1.3 The application ERCO & GENER EasePro_Vx - § 7.2.2.2 Specifications of the internal battery - § 9.1 General security The GenPro 53e AOB becomes the GenPro 53e. Page 23, the modem does not FAX. Updating limits - 8.2.2.3 Buzzer - § 8.2.3.3 Analog input Preparation of the modem for storage - § 5.9 Turning off the modem - § 7.2.2 Internal battery - § 8.2.1 Power supply	YST	05/07/11

The main modifications of this document compared to the previous version are easily identifiable on the screen by the blue color of the text.

TABLE OF CONTENTS

PRESENTATION	7
WARNING	8
COPYRIGHT	9
1 REFERENCES	10
1.1 REFERRED DOCUMENTS	10
1.2 ABBREVIATIONS	10
1.3 SYMBOLS	12
2 PACKAGING	13
2.1 CONTENT	13
2.2 PACKING CASE	14
2.3 MODEM LABEL	14
3 GENERAL PRESENTATION	15
3.1 DESCRIPTION	15
3.1.1 Front side	15
3.1.2 Back side	15
3.1.3 Fixing brackets	16
3.2 EXTERNAL CONNECTIONS	17
3.2.1 Connections	17
3.2.1.1 Antenna connectors	17
3.2.1.2 Micro FIT connectors	17
3.2.1.3 Audio connector	19
3.2.2 Cables	20
3.2.2.1 4-wire micro FIT cable	20
3.2.2.2 14-wire micro FIT cable	21
3.2.2.3 16-wire micro FIT cable	22
4 CHARACTERISTICS AND SERVICES	23
5 USING THE MODEM	25
5.1 STARTING WITH THE MODEM	25
5.1.1 Mounting the modem	25
5.1.2 Installation of the modem	25
5.1.3 Checking the communication with the modem	26
5.1.3.1 Without Application	26
5.1.3.2 Standard library	27

- 5.1.3.3 The application ERCO & GENER [EasePro_Vx](#) 27
- 5.1.3.4 The owner application 28
- 5.1.4 SIM card extraction 28
- 5.1.6 Hardware reset of the modem 28
- 5.2 SPECIFIC RECOMMENDATIONS FOR THE USE OF THE MODEM IN VEHICLES..... 28
 - 5.2.1 Recommended connection on the battery of a truck 29
 - 5.2.2 Technical constraints in trucks..... 30
- 5.3 MODEM LEADS 31
 - 5.3.1 GSM led 31
 - 5.3.1.1 Without application 31
 - 5.3.1.2 With standard library..... 31
 - 5.3.1.3 The application ERCO & GENER [EasePro_Vx](#) 31
 - 5.3.1.4 The owner application 31
 - 5.3.2 Led 3 31
 - 5.3.3 Led 4 31
 - 5.3.4 Led 5 32
 - 5.3.5 LED 6 32
- 5.4 ECHO FUNCTION OF THE DEACTIVATED AT COMMANDS 32
- 5.5 CHECKING THE QUALITY OF THE GSM RECEPTION SIGNAL..... 32
- 5.6 VERIFICATION OF THE PIN CODE..... 33
- 5.7 VERIFICATION OF THE MODEM REGISTRATION ON THE GSM NETWORK..... 34
- 5.8 MAIN AT COMMANDS (HAYES) 35
- 5.9 TURNING OFF THE MODEM 36
- 5.10 MODEM UPDATING PROCEDURE 36
- 6 TROUBLE SHOOTING..... 37
 - 6.1 PROBLEM OF COMMUNICATION BETWEEN THE MODEM AND THE RS232 LINK (V24) 37
 - 6.2 "ERROR" MESSAGE 38
 - 6.3 "NO CARRIER" MESSAGE..... 38
- 7 FUNCTIONAL DESCRIPTION 40
 - 7.1 ARCHITECTURE..... 40
 - 7.2 POWER SUPPLY 40
 - 7.2.1 General presentation 40
 - 7.2.2 Internal battery 41
 - 7.2.2.1 Presentation of the internal battery 41
 - 7.2.2.2 Specifications of the internal battery 41
 - 7.2.2.3 Charge voltage and supply voltage 41
 - 7.2.2.4 Indication of presence/absence of the external power supply 42
 - 7.2.2.5 Instructions and restrictions of use 42

7.2.3 Protections of the power supply.....	43
7.3 RS232 SERIAL LINK	43
7.3.1 General Presentation	43
7.3.2 Serial link RS232_0	43
7.3.3 Serial link RS232_1	44
7.3.4 Serial link RS232_2 / Bus CAN	45
7.3.4.1 RS232_2.....	45
7.3.4.2 Bus CAN	46
7.4 INPUTS/OUTPUT FUNCTIONING.....	46
7.4.1 Management of logical outputs	47
7.4.2 Management of logical inputs	47
7.4.3 Management of analog inputs	48
7.5 OPTION 2 ND SIM CARD READER.....	48
7.6 BOOT.....	48
7.7 RESET	48
7.7.1 General presentation	48
7.7.2 RESET Sequence.....	49
7.8 WATCHDOG	50
7.9 AUDIO	50
7.9.1 Microphone inputs.....	50
7.9.2 Loud-speaker outputs (Speaker)	51
7.9.3 Buzzer outputs	51
7.10 ACCELEROMETER	52
7.11 INTERNAL PROCESSOR.....	52
7.11.1 EGM presentation	52
7.12.2 EGM architecture	53
8 TECHNICAL CHARACTERISTICS	54
8.2 ELECTRICAL CHARACTERISTICS	55
8.2.1 Power supply	55
8.2.1.1 Consumption of the board with battery charged.....	56
8.2.1.2 Consumption of the board with battery charging.....	56
8.2.1.3 Consumption of the RS 232	57
8.2.1.4 Consumption of the GSM module	57
8.2.2 Audio interface	58
8.2.2.1 Microphone	58
8.2.2.2 Loudspeaker	59
8.2.2.3 Buzzer.....	60
8.2.3 Inputs/Output	61
8.2.3.1 Opto-coupled inputs	61

8.2.3.2 Output	62
8.2.3.3 Analog input.....	63
8.2.4 SIM interface	63
8.2.5 Option 2 nd SIM interface	63
8.2.6 RESET signal.....	64
8.2.7 Characteristics of the RS232 serial links	64
8.2.8 RF GSM/DCS characteristics	65
8.2.8.1 RF functioning	65
8.2.8.2 GSM external antenna.....	65
8.2.9 Power supply 3.8 V	66
8.2.10 Power_Out power supply.....	66
8.2.11 Option 100V power supply.....	66
8.3 ENVIRONMENTAL CHARACTERISTICS	66
8.4 STANDARDS/CONFORMITIES	67
9 SECURITY RECOMMENDATIONS	68
9.1 GENERAL SECURITY	68
9.2 SECURITY IN A VEHICLE	69
9.3 CARE AND MAINTENANCE	69
9.4 YOUR RESPONSIBILITY	69
10 RECOMMENDED ACCESSORIES.....	70
11 CLIENT SUPPORT.....	70
DECLARATION OF CONFORMITY.....	71

Presentation

Entirely dedicated to the wireless markets throughout the world, the [GenPro 53e](#) (Application On Board) allows a simple and rapid integration of GSM / GPRS Quad-Band (850/900/1800/1900 MHz) connectivity into M2M applications.

The [GenPro 53e](#) is a robust, reliable and long life product. Its very compact metal case makes it ideally adapted to onboard standards.

The modem is Quad-Bands (850/900/1800/1900 MHz) GSM/GPRS Class 10 or EDGE*.

The [GenPro 53e](#) has 3 operating modes:

- External mode (standard): The driving is made by an external application. The modem is used with the AT commands set (see Commands List [EG_EasePro_Vx_CL_yyy_UK](#) of ERCO & GENER).
- Autonomous mode (optional): Once configured, the modem is autonomous, it cyclically registers the positions and transmits them automatically to the client's application via different services: SMS, GSM Data, TCP socket GPRS (see [EG_EasePro_Vx_CL_yyy_UK](#) of ERCO & GENER).
- Specific development mode: the EGM development tool allows to develop personalized embedded application. For more information concerning the tools and the training, please contact our sales department.

By default, the [GenPro 53e](#) provides:

2 RS232ports,
a 1-Wire interface
TOR inputs/outputs, 5 inputs, 3 outputs
2 analogs inputs
a back-up battery
a 3-axis accelerometer

The [GenPro 53e](#) can be equipped with the options Bus CAN and DUAL SIM.

Its protocols of IP connectivity integrated in the embedded application EasePro, are also available under EGM libraries for a specific development, allowing a quick installation of embedded telematic solutions with high added-value.

This document describes the modem and provides the following information:

- General presentation,
- Functional description,
- Available basic services,
- Installation and use of the modem (first level),
- Trouble shooting,
- Recommended accessories for the use of the modem.

For more information concerning this document, ERCO & GENER puts at your disposal the following elements:

- Commands List
 - External Mode [EG_EGM_CL_xxx_yy](#)
 - Autonomous Mode [EG_EasePro_Vx_CL_yyy_UK](#)
- Application Note [EG_GenPro53e_1040_AN_xxx_yy](#)
- Release Note [EG_GenPro53e_1040_RL_xxx_yy](#)
- Client support (Hot-Line)

Warning

- ERCO & GENER advises to read carefully all the documents concerning the [GenPro 53e](#) (User Guide, Application Notes, Command List).
 - ERCO & GENER cannot be held responsible for:
 - The problems due to an inappropriate use of the [GenPro 53e](#).
 - The problems due to a wrong configuration
 - The problems due to a wrong use of an embedded software application developed or supplied by a third party.
 - The dysfunctions due to the absence or a bad coverage of the GSM, GPRS networks.
 - The dysfunctions if the product is used for the watching of physical persons where human life is engaged.
 - ERCO & GENER reserves the right to modify the functions of its products "[GenPro 53e](#)" and "EasePro" without previous notice.
- In order to avoid any risk of electrocution, do not open the casing.
- For any functioning, the casing must be closed.
- No internal part can be repaired by the user. The [GenPro 53e](#) must be returned to the factory for any repair.
- The [GenPro 53e](#) must be placed in a normally ventilated area, out of sources of heat.
- In order to guarantee the electromagnetic compatibility, the length of the serial cable, the supply cable and the inputs/outputs cable must not exceed 3 meters.
- The [GenPro 53e](#) must not be connected directly to the mains supply; a voltage adapter must be used.



SCRAP THE WORN BATTERIES ACCORDING TO INSTRUCTIONS.

Copyright

The reproduction, transfer, distribution or storage of part or the totality of the contents of this document, in any form, without the prior written authorization of ERCO & GENER is strictly prohibited.

GenPro 53e is a trademark of ERCO & GENER.

Hayes is a registered trademark of Hayes Microcomputer Product Inc. The names of products and companies mentioned in this document may be names or trademarks of their respective holders.

The use of some products or services described in this document may require a paying subscription. The availability of some products or services described in this document may change, depending on the configurations and the materials.

In some countries, restrictions of use of the devices may be applied. For more information, thank you to contact your nearest legally qualified local government representative.

ERCO & GENER follows a method of continuous development. Consequently, ERCO & GENER reserves the right to change and improve any of its products described in this document, without notice.

The contents of this document are provided "as it is". Except for the applicable obligatory laws, no guarantee in any form, explicit or implicit, including but without being limited to it the implicit guarantees of aptitude to marketing and of appropriateness to a particular use, is granted concerning the precision, the liability or the contents of this document. ERCO & GENER reserves the right to revise or withdraw this document at any time and without notice.

ERCO & GENER cannot be held responsible for any loss of data or income, as well as particular damage, incidental, consecutive or indirect.

1 References

1.1 Referred documents

Commands List of	
Standard library of ERCO & GENER.....	EG_EGM_CL_xxx_yy
The embedded application EasePro of ERCO & GENER.....	EG_EasePro_Vx_CL_yyy_UK
Application Notes of GenPro 53e of ERCO & GENER.....	EG_GenPro53e_1040_AN_xxx_yy

GSM reference documents:

- GSM 07.05.
- GSM 07.07.

1.2 Abbreviations

Abbreviations Definition

AC	Alternative Current
ACM	Accumulated Call Meter
AMR	Adaptive Multi-Rate
AT	Attention (prefix for modem commands)
BTS	Base Transceiver Station
CLK	Clock
CMOS	Complementary Metal Oxide Semiconductor
CS	Coding Scheme
CTS	Clear To Send
dB	Decibel
dBc	Decibel relative to the Carrier power
dB _i	Decibel relative to an Isotropic radiator
dBm	Decibel relative to one milliwatt
DC	Direct Current
DCD	Data Carrier Detect
DCE	Data Communication Equipment
DCS	Digital Cellular System
DSR	Data Set Ready
DTE	Data Terminal Equipment
DTMF	Dual Tone Multi-Frequency
DTR	Data Terminal Ready
EEPROM	Electrically Erasable Programmable Read-Only Memory
EFR	Enhanced Full Rate
EGM	Erco Gener Middleware
E-GSM	Extended GSM
EMC	ElectroMagnetic Compatibility
EMI	ElectroMagnetic Interference
ESD	ElectroStatic Discharges
ETSI	European Telecommunications Standards Institute
FIT	Series of connectors (micro-FIT)
FR	Full Rate
FTA	Full Type Approval
FTP	File Transfert Protocol
GCF	Global Certification Forum
GND	GrouND
GPIO	General Purpose Input Output

GPRS	General Packet Radio Service
GPS	Global Positioning System
GSM	Global System for Mobile communications
HR	Half Rate
I	Input
IEC	International Electrotechnical Commission
IMEI	International Mobile Equipment Identification
I/O	Input / Output
LED	Light Emitting Diode
LLC	Low Level Command
MAX	MAXimum
ME	Mobile Equipment
MIC	MICrophone
Micro FIT	Family of connectors from Molex
MIN	MINimum
MNP	Microcom Networking Protocol
MO	Mobile Originated
MS	Mobile Station
MT	Mobile Terminated
NOM	NOMinal
O	Output
Pa	Pascal (for speaker sound pressure measurements)
PBCCH	Packet Broadcast Control Channel
PC	Personal Computer
PCL	Power Control Level
PDP	Packet Data Protocol
PIN	Personal Identity Number
PLMN	Public Land Mobile Network
PUK	Personal Unblocking Key
RF	Radio Frequency
RFI	Radio Frequency Interference
RI	Ring Indicator
RMS	Root Mean Square
RTS	Request To Send
RX	Receive
SIM	Subscriber Identification Module
SMA	SubMiniature version A RF connector
SMB	SubMiniature version B RF connector
SMS	Short Message Service
SNR	Signal-to-Noise Ratio
SNTP	Simple Network Time Protocol
SPI	Serial Peripheral Interface
SPL	Sound Pressure Level
SPK	SpeaKer
SRAM	Static RAM
TCP/IP	Transmission Control Protocol / Internet Protocol
TDMA	Time Division Multiple Access
TU	Typical Urban fading profile
TUHigh	Typical Urban, High speed fading profile
TX	Transmit
TYP	TYPical
UTC	Universal Time Clock
VSWR	Voltage Stationary Wave Ratio

1.3 Symbols

The following symbols are used to highlight the important information of this userguide.



A symbol for the essential information concerning the module integration and performance.



A warning symbol indicates the actions that could harm or damage the module

2 Packaging

2.1 Content

The **GenPro 53e** is supplied:

- a **GenPro 53e** cardboard packaging,
- a modem **GenPro 53e**,
- 2 fixing brackets,
- a 4-wire supply cable, input/output (Red/Black/Yellow/Brown) stripped with fuse.
- a 14-wire stripped cable Inputs/outputs with 14 pins connector.
- a 16-wire cable serial link equipped with a with 16 pins connector, a sub D 9 pins and stripped wires.
- a technical sheet (Instructions Sheet).



2.2 Packing case

The external dimensions of the packing case are:

- Width : 160 mm,
- Height: 280 mm,
- Length: 64 mm.

A packaging label is placed on the side of the case. It shows:

- The logo ERCO & GENER,
- The product reference: [GenPro 53e](#),
- The CE mark,
- The IMEI bar code with 15 digits.

The dimensions of the label are:

- Height : 37 mm,
- Length : 70 mm.



Example of label placed on the packaging

2.3 Modem label

On the standard casing, there are 2 labels placed on the back part of the modem:

- A production label indicating the following information: (see picture 3.1.3 Fixing brackets)
 - The CE mark,
 - The crossed wheelie-bin mark (DEEE standards),
 - The direct current mark (VDC),
 - The IMEI bar code with 15 digits.

If the internal battery option has been mounted during production, the modem has the following label: Lithium-Polymer Battery Inside.



3 General presentation

3.1 Description

Description of the modem [GenPro 53e](#):

3.1.1 Front side

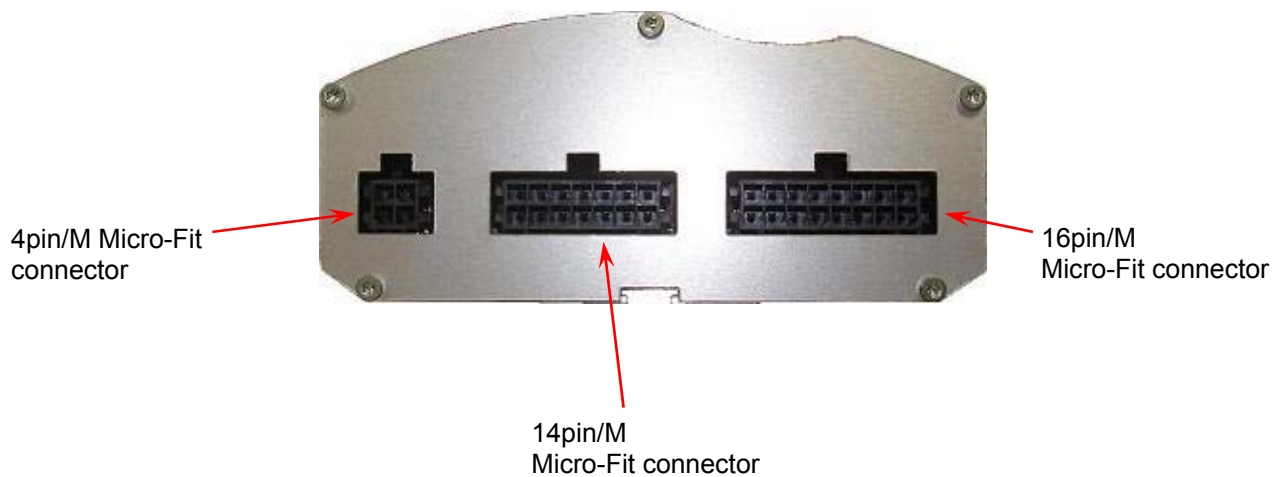

3.1.2 Back side

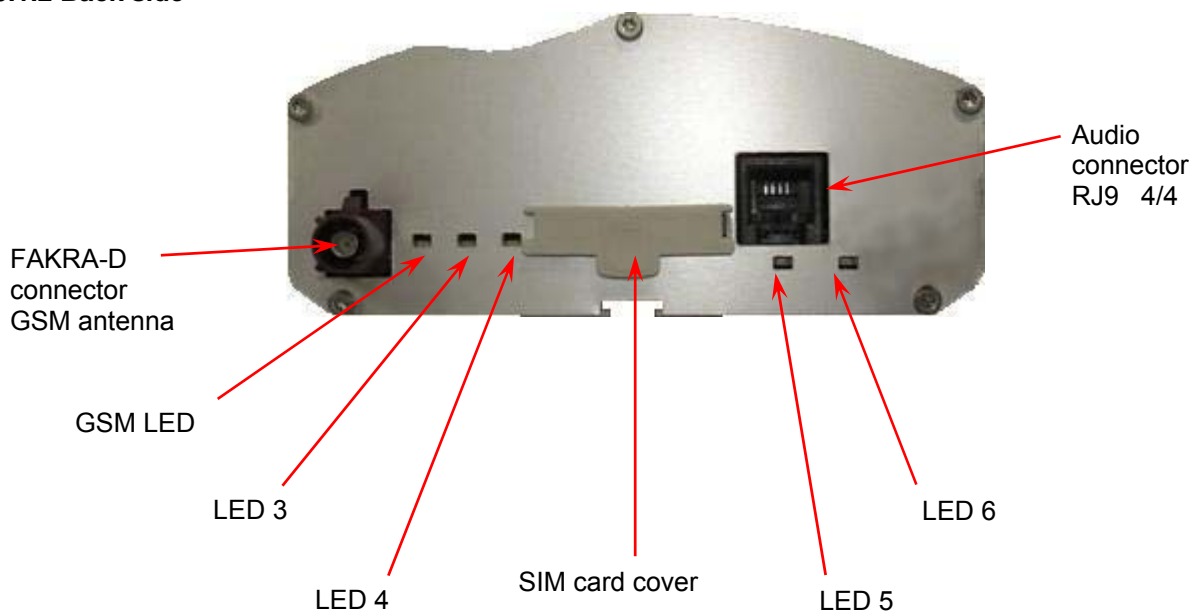

3.1.3 Fixing brackets

2 brackets to fix the modem on a support.

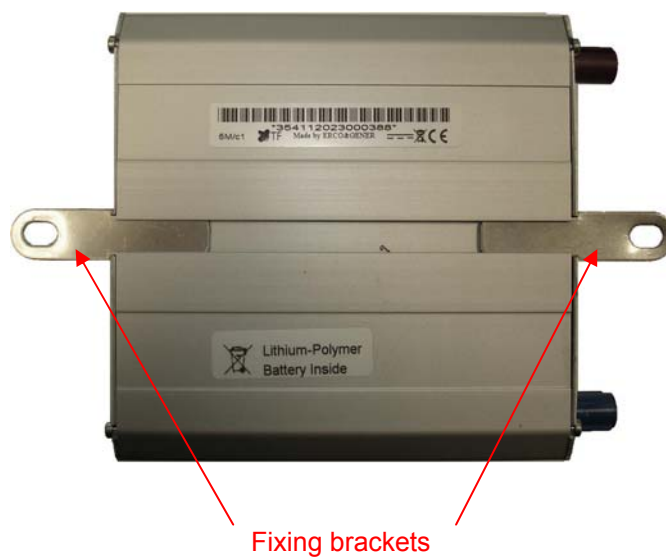

3.2 External connections

3.2.1 Connections

3.2.1.1 Antenna connectors

GSM antenna connector:

The GSM antenna connector is FAKRA D male with a 50Ω impedance.

3.2.1.2 Micro FIT connectors

Female Micro FIT connector with 4 male pins:

This connector of the [GenPro 53e](#) is a connector for the DC external supply and the GPIOs (the 2 signals Input and Output).

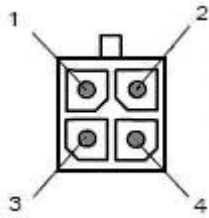

Pin N°	Signal
1	+VDC
2	GND
3	Logical INPUT 1 (E1)
4	Logical OUTPUT 1 (S1)



The pins 3 and 4 are used for the Input/Output functions. The modem can only be powered by the pins 1 (+VDC) and 2 (GND). You must use the supply cable provided with the modem. It ensures the protection of the equipment.

Female Micro FIT connector with 14 male pins:

This connector of the **GenPro 53e** is a connector for the inputs, logical and analog outputs.

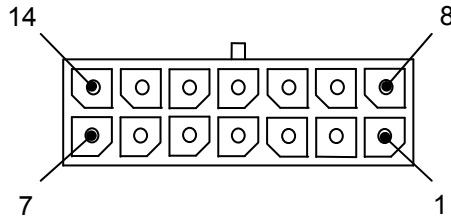

Pin N°	type	Nature	Signal
1	I/O	Logical	ONE_WIRE
2	Input	Analog	ANA2
3	---	---	GND
4	Input	Logical	E5
5	Input	Logical	E4
6	Output	Logical	S3
7	Output	Analog	+ 3.8 V
8	---	---	GND
9	Input	Analog	ANA1
10	---	---	GND
11	Input	Logical	E3
12	Input	Logical	E2
13	Output	Logical	S2
14	Output	Analog	BUZZER

Option*
Input E5 insulated
common GND except for E3, E5
Input E3 insulated
BUZZER

* Contact us

3.2.2 Cables

3.2.2.1 4-wire micro FIT cable

(ERCO & GENER reference: 4402304215)

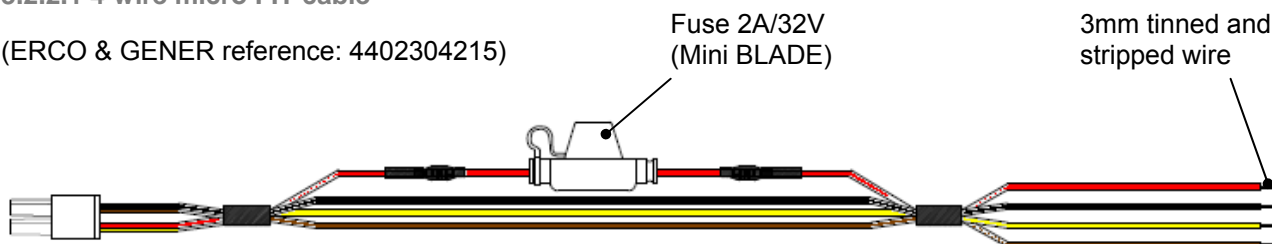

View from cable side

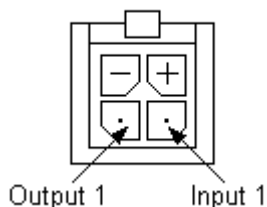

Component	Characteristics
4-pin connector	
Cable	Length ≈ 1.5m
Wire	Section : 0.75 mm ²
Fuse	F2A - 32V

Signal	Color
+VDC	Red
GND	Black
INPUT 1 (E1)	Yellow
OUTPUT 1 (S1)	Brown

Fuse reference: Mini Blade pour car 2A - 32V (code couleur : grey)

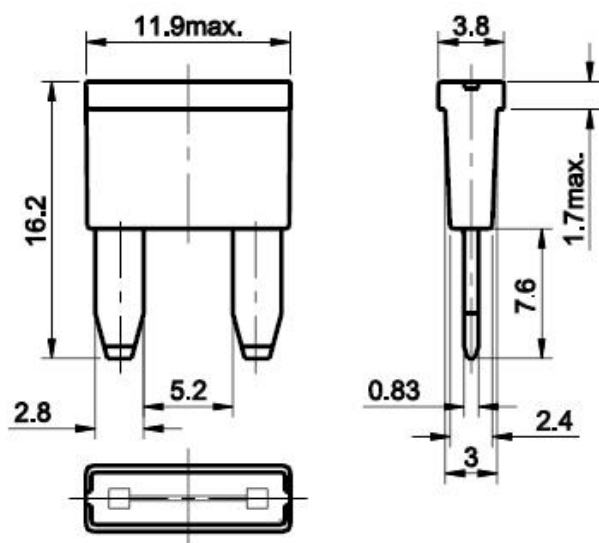

3.2.2.2 14-wire micro FIT cable

(ERCO & GENER reference: 4402314215)

3mm tinned
stripped wire
(Mini BLADE)

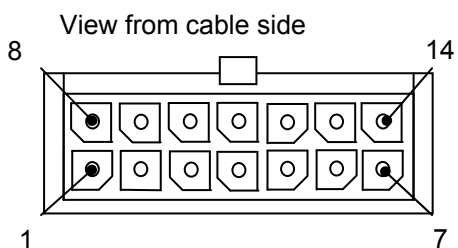

Component	Characteristics
14-pin connector	
Cable	Length ≈ 1.5m
Wire	Section : 0.5 mm ²

Pin N°	Signal	Color
1	ONE_WIRE	White/Green
2	ANA2	Grey
3	GND	Black
4	E5	Blue
5	E4	Green
6	S3	White/Yellow
7	+ 3.8 V	Orange
8	GND	Black
9	ANA1	Violet
10	GND	Black
11	E3	Yellow
12	E2	Brown
13	S2	White / Brown
14	BUZZER	Red

3.2.2.3 16-wire micro FIT cable

(ERCO & GENER reference : 4404314215)

3mm tinned and
stripped wire
(Mini BLADE)



Component	Characteristics
16-pin connector	
Cable	Length ≈ 1.5m
Wire	Section : 0.5 mm ²
Sub D 9-pin female	

View from cable side

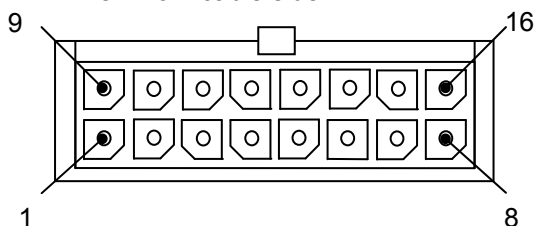

Pin N°	Signal	Color	Sub D 9-pin
1	GND	Black	---
2	TX_2 / CANH	Violet	---
3	RX_2 / CANL	White/Violet	---
4	GND	Black	---
5	CTS_1	White /Brown	---
6	RTS_1	White /Yellow	---
7	TX_1	White /Green	---
8	RX_1	White /Blue	---
9	POWER_OUT	White	---
10	RESET	---	---
11	BOOT	---	---
12	GND	Black	5
13	CTS_0	Brown	8
14	RTS_0	Yellow	7
15	TX_0	Green	3
16	RX_0	Blue	2
	---	---	9
	---	---	6
	---	---	4
	---	---	1

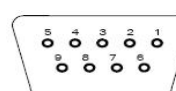

4 Characteristics and Services

The [GenPro 53e](#) is:

A class10 GSM/GPRS modem dedicated to asynchronous binary data transmission, [Group3 \(Class 2\)](#), SMS and voice.

The modem characteristics and the available services are summarized in the table below.

GSM functions
- Quad-Bands 850/900/1800/1900 MHz
- ETSI GSM Phase 2+ Class 4 (2W @ 850 / 900 MHz) Class 1 (1W @ 1800 / 1900 MHz)
- SIM Toolkit Release 99
VOICE functions
- Voice (GSM mode)
- Telephony, Emergency call 112
- Full Rate, Enhanced Full Rate, Half Rate and AMR (FR/EFR/HF/AMR)
- Echo cancelation and noise reduction
- Full Duplex Free-hand
DATA functions
- GPRS Class 10 (Up to 4Rx / 2Tx)
- PBCCH/PCCCH supported, Coding scheme : CS1 to CS4
- TCP/IP library (PPP, TCP Socket, UDP Socket*, FTP, SMTP*)
- Asynchronous data circuit, transparent and non-transparent 9600 (Standard) at 14400bds (depending on network)
- SMS Text, PDU, point to point MT/MO and SMS Cell Broadcast
Interfaces
- GSM antenna: connector FAKRA-D
- Power supply : +5.5 to +32 VDC (micro-FIT connector)
- 1 serial port RS232_0 (300 to 115200bds) Sub-D 9 pin female
- 1 serial port RS232_1 (300 to 115200bds)
- AT commands: GSM 07.05 et 07.07
- SIM reader (SIM 3V – 1,8V)
- 5 opto-coupled inputs
- 3 open-collector outputs
- 2 analog inputs (0 – 10 Volts)
- External Auto-supply controlable (connector 16 pins micro-FIT)
- Buzzer output (connector 14 pins micro-FIT)
- Back-up battery
- 1 port ONE_WIRE
- supply output 3.8 V
- 3-axis accelerometer
- Audio

Accessories supplied
- Fixing brackets (x2)
- 4-wire Micro FIT cables (Power supply, Input and Output)
- 14-wire Micro FIT cables (Input and Output)
- 16-wire Micro FIT cables (serial ports)
Options / Accessories *
- Power supply 100 Volts
- Direct logical inputs
- Powering on controllable by HTR
- Bus CAN (Cango) standards protocol FMS
- Bus CAN low layer : without protocol
- Input 3 and 5 insulated
- Inhibit charge of the battery
- Double SIM card
- ONE WIRE in bus I2C
- 3 rd UART
- Reinforced protection of inputs / outputs
- Accessories: Antennas, cables, power supply... (consult our website)

* contact us

5 Using the modem

5.1 Starting with the modem

5.1.1 Mounting the modem

To mount the modem on a support, use the fixing brackets as described below.

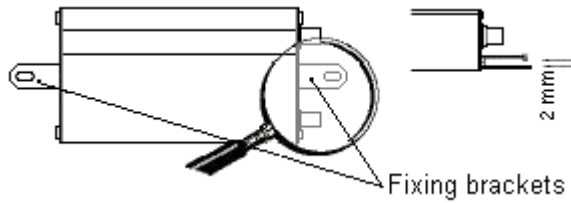

- Must be fixed on a flat surface
- Max. height of the screw head: 2 mm



The aluminum casing of the modem is connected to the 0V (GND) of the power supply and to the 0V of the RS232 serial link. To avoid any risk of conduction of the ground plane to other equipments, the modem must be electrically insulated from its mechanical support.

5.1.2 Installation of the modem

To install the modem, it is recommended to do the following operations with the modem turned off:

- Remove the SIM card cover on the rear side.
- Carefully insert the SIM card into the reader.

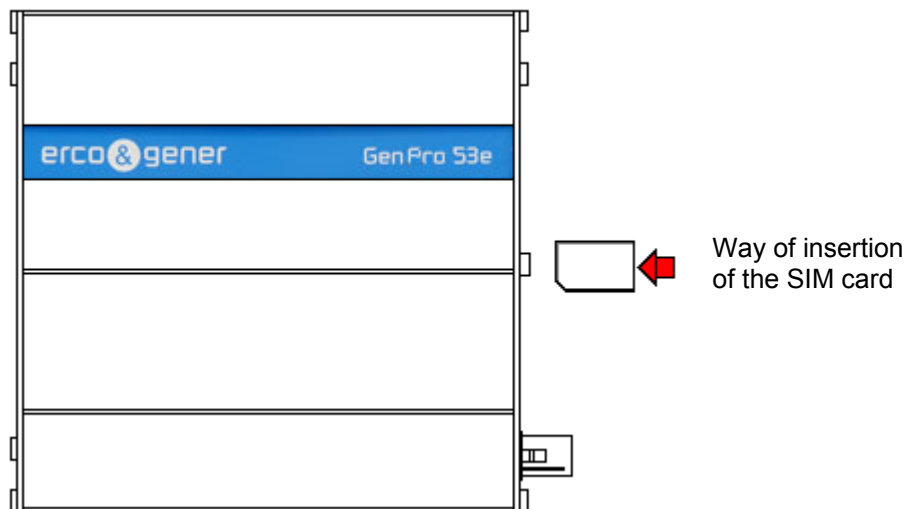

- Push the SIM card until hearing a "clac" that ensures its correct positioning.
- Put the SIM cover back.

- Connect the GSM antenna to the FAKRA-D connector.
- For the connection to the DTE, connect the V24 link via the 9-pin Sub D cable.
- Connect the supply cable to the continuous and regulated power source (for an automobile application, see the paragraph 5.2).
- Connect the supply cable to the modem and turn on the external power supply.

The modem is now ready.

There are 4 different displays depending on the application installed inside the equipment:

- Without application: corresponds to Boot_Loader.
- Standard library.
- The application ERCO & GENER [EasePro_Vx](#).
- The owner application.

5.1.3 Checking the communication with the modem

5.1.3.1 Without Application

The [GenPro 53e](#) does not contain any application; it will return the menu of the Boot-Loader.

Connect the link RS232 between the DTE (the COM port) and the modem (DCE).

Set the RS232 port of the DTE as follows:

- Bits per second: 115 200 bps,
- Data bits: 8,
- Parity: None,
- Stop bits: 1,
- Flow control: material.

Use a communication software like HyperTerminal ® of Windows.

Menu by default when there is no application inside the equipment (example of display)

```
Bootloader V2.39 GL53 UA GenLoc53e ENF (HW16 rev B/C)
```

```
GSM voltage = 4347 mV
```

- ```
1 - Update application
2 - Erase objects
M - GSM direct access
A - Advanced
P - Power off
E - Exit
```

In the case where no communication can be established with the modem:

- Check the RS232 connection between the DTE and the modem (DCE),
- Check the configuration of the COM port of the DTE.

5.1.3.2 Standard library

The [GenPro 53e](#) contains the standard library.

Connect the RS232 link between the DTE (the COM port) and the modem (DCE).

Set the RS232 port of the DTE as follows:

- Bits per second: 115 200 bps,
- Data Bits: 8,
- Parity: None,
- Stop Bits: 1,
- Flow control: material.

Use a communication software like HyperTerminal ® of Windows.

[Example of display Menu by default](#) when the standard library is present inside the equipment ([example of display](#))

```

Starting egm_clientAppli: initType = 0x0003
Wait for "+EGEVT: 2" before starting IP tests"
+EGEVT: 0
+EGEVT: 7
+EGEVT: 22
Send the command AT+EGM3
The modem returns the version of the library
LIB: genapi_ipc V2.25b1, Date: Tue Mar 15 09:21:51 2011
```

In the case where no communication can be established with the modem:

- Check the RS232 connection between the DTE and the modem (DCE),
- Check the configuration of the COM port of the DTE

For more information about these AT commands and their associated parameters, see the documents "Commands List EG\_EGM\_CL\_xxx\_yy" of ERCO & GENER.

5.1.3.3 The application ERCO & GENER [EasePro\\_Vx](#)

The [GenPro 53e](#) contains the application [EasePro\\_Vx](#).

[Send the commande ATi8. The modem returns the version \(example of display\)](#)

```
EaseLoc V2.10b1 GenLoc53e-AOB eCos-Enabler IIIG_GSM0308-Thu Mar 17 10:29:40 2011
```

[For more information about these AT commands and their associated parameters, see the documents "Commands List EG\\_EaseLoc\\_Vx\\_CL\\_yyy\\_UK" of ERCO & GENER.](#)

#### 5.1.3.4 The owner application

Le [GenPro 53e](#) contains your application.

Connect the RS232 link between the DTE (the COM port) and the modem (DCE).

Set the RS232 port of the DTE according to your parameters (speed, data bits, parity and stop bit).

Use a communication software like HyperTerminal ® of Windows.

Check the display and the dialogue with the [GenPro 53e](#) according to your own characteristics.

#### 5.1.4 SIM card extraction

To remove the SIM card from the modem, it is recommended to do the following operations with the modem turned off:

- Remove the SIM card cover on the rear side.
- Press the SIM card (simple pressure) until hearing a "clac" that ensures its ejection.
- Remove delicately the SIM card from the reader.
- Put the SIM cover back.

#### 5.1.6 Hardware reset of the modem

To trigger a Hardware reset of the modem, a RESET signal (hardware) is available on the pin 10 of the 16-pin Micro-FIT connector (RESET).

The modem Reset is made when the RESET signal (pin 10) is held at a low level during 10ms.



This signal must be considered as a way of resetting the modem in case of emergency only. For more details concerning the modem RESET, see the paragraph 7.7.2 RESET sequence



See the table of the paragraph 8.2.6 RESET signal for the electrical characteristics.

## 5.2 Specific recommendations for the use of the modem in vehicles



The power supply connector of the modem [GenPro 53e](#) must **NOT** be connected directly to the battery of the vehicle.

### 5.2.1 Recommended connection on the battery of a truck

All lorries have a Circuit Breaker outside the cabin. The circuit breaker is used for security reasons: for example, if a fire breaks out in the electric box of the lorry, the driver can cut off the power source and avoid more damage (explosion).

The circuit breaker is connected to the ground of the lorry, usually connected to the fuse box.

Most of lorry circuit breakers do not cut off the PLUS of the battery, but cut off the ground.

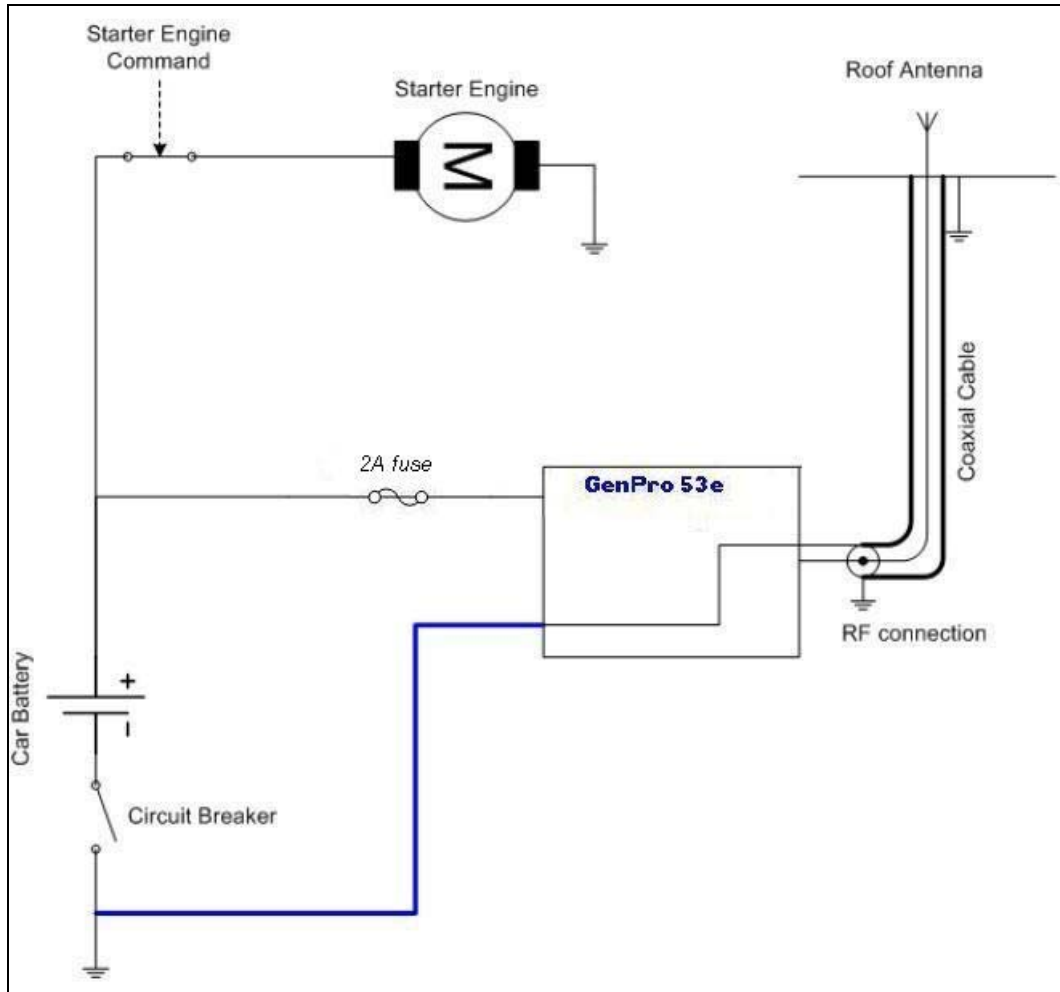

The scheme above shows a recommended power connection where the connection of the modem ground is not directly connected to the battery, but connected after the circuit breaker (to the ground of the lorry or in the fuse box).

5.2.2 Technical constraints in trucks

It is highly recommended **NOT** to connect the modem supply directly to the battery but to the circuit breaker. Otherwise the modem can be damaged when the lorry is starting up if the circuit breaker is closed (in this case, the ground of the lorry and the ground of the battery will be connected via the modem as described in the scheme below).

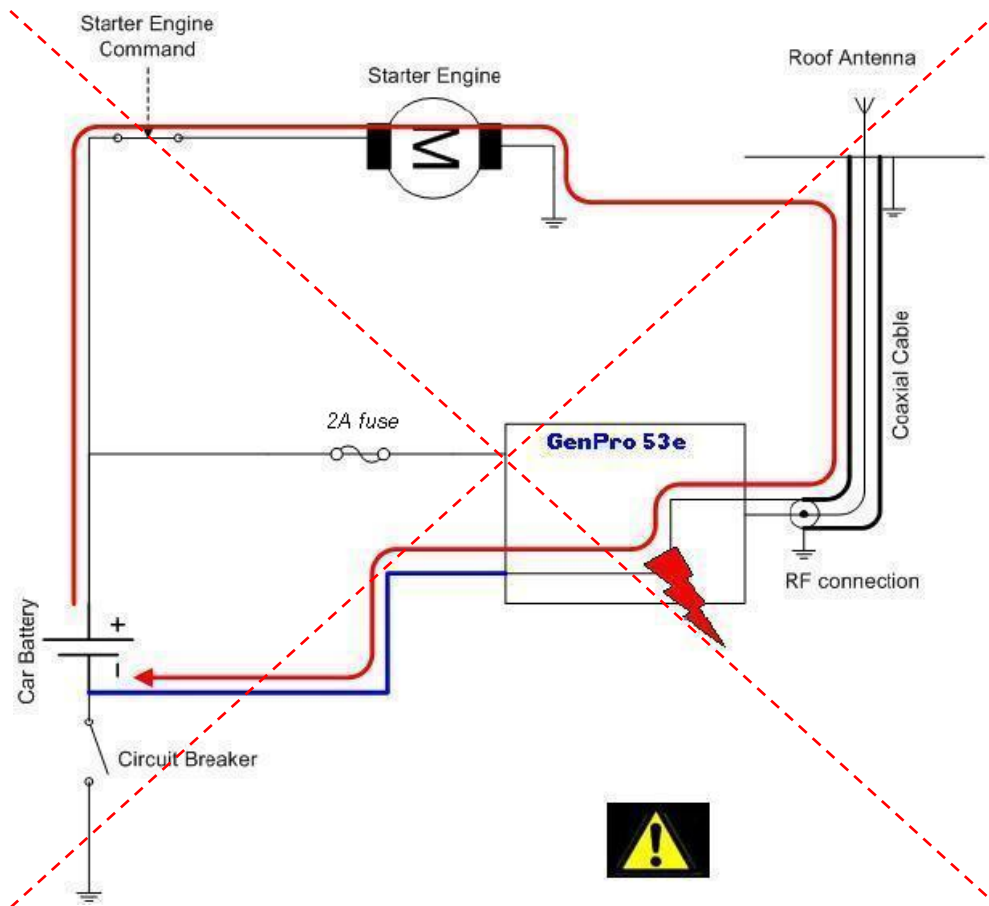

Example of forbidden electrical connection (risk of damage on the modem)

The scheme above shows an example of electrical connection that could damage the modem due to the fact that the ground connection is directly connected to the battery ground.

In fact in this example, when the circuit breaker is open, the current escapes via the modem and the electrical circuits of the lorry (the dashboard for example). And when the motor's starter is used, it will destroy the cables or the modem.

Moreover, the internal circuits of the modem are not designed to resist to a current of 60 A (when starting the lorry), or they would be destroyed.

## 5.3 Modem leds

### 5.3.1 GSM led

#### 5.3.1.1 Without application

The [GenPro 53e](#) does not contain any application. The led is off.

#### 5.3.1.2 With standard library

The [GenPro 53e](#) contains the standard library. The led is off.

#### 5.3.1.3 The application ERCO & GENER [EasePro\\_Vx](#)

The GSM status module is indicated by the GSM LED located on the rear side of the modem. (see paragraph 3.1.2 Back side).

| GSM LED status | LED activity       | GSM status                                          |
|----------------|--------------------|-----------------------------------------------------|
| Off            | LED off            | The module is not activated or power off.           |
| On             | LED on             | The module is being attached to the GSM network.    |
| LED flashing   | 0.5s ON / 1.5s OFF | The module is attached to the GSM network.          |
| LED flashing   | 0.2s ON / 0.6s OFF | The module is in communication data, voice or GPRS. |

#### 5.3.1.4 The owner application

The [GenPro 53e](#) contains your application. The led status depends on your parameters.

### 5.3.2 Led 3

This led is free. It is left at the user's disposal. It is controlled via a command through the ARM. This command is currently under development. Contact us.

### 5.3.3 Led 4

This led is free. It is left at the user's disposal. It is controlled via a command through the ARM. This command is currently under development. Contact us.

### 5.3.4 Led 5

This led is free. It is left at the user's disposal. It is controlled via a command through the ARM. This command is currently under development. Contact us.

### 5.3.5 LED 6

This led is not used.

## 5.4 Echo function of the deactivated AT commands

The modem contains the EGM standard library (see the documents "EG\_EGM\_CL\_xxx\_yy" of ERCO & GENER) in this case, if no echo is returned when entering an AT command, it means that:

- the "local echo" of your communication software (like Hyperterminal) is not activated,
- the echo function of the modem has been deactivated.

The echo function can be set with the command **ATE**, it requires a back-up with the command **AT&W**.

To activate the echo function of the modem, enter the command **ATE1**.

When sending AT commands to the modem using a communication software, it is recommended to:

- Deactivate the "local echo" parameter in your communication software (like Hyperterminal),
- Activate the echo function of the modem (the command **ATE1**).

For a communication Machine to Machine with the modem, it is recommended to deactivate the echo function of the modem (the command **ATE0**) in order to avoid the CPU receiving redundant responses.

For more information about the **ATE** commands, see the document "EG\_EGM\_CL\_xxx\_yy" of ERCO & GENER.

## 5.5 Checking the quality of the GSM reception signal

The modem contains the EGM standard library (see the documents "EG\_EGM\_CL\_xxx\_yy" of ERCO & GENER) in this case, the modem will be able to make a call only if the received GSM signal is sufficient.

The command **AT+CSQ** allows to know the reception level (**rsst**) of the signal sent by the closest GSM Base Transceiver Station (BTS), as well as the reception error code (**g**).

When the SIM card is inserted and the PIN code entered, the command **AT+CSQ** allows to measure the signal from the BTS of the subscribed operator network..

This command can also be used without the SIM card, it indicates in this case the nearest BTS which can be ORANGE, SFR or BOUYGUES for France (Without SIM card, the current subscription is not recognized).It is therefore advisable to do the measure when the SIM card is present.



To check the quality of the GSM signal, do the following operations:

Use a communication software like Hyperterminal, enter the command **AT+CSQ**.

The response is in the following format:

**+CSQ : <rss>, <ber>** with:

**<rss>** = indicates the reception level,

**<ber>** = receive bit error rate.

Check the returned value **<rss>** with the help of the table below.

| <rss> value | Gain in dbm     | Interpretation         | <ber> value | Interpretation               |
|-------------|-----------------|------------------------|-------------|------------------------------|
| 0           | -113 dbm        | Insufficient           | 0 to 7      | See standards ETSI GSM 05.08 |
| 1 to 10     | -111 to -95 dbm | Insufficient           |             |                              |
| 11 to 30    | -93 to -53 dbm  | Sufficient             |             |                              |
| 31 (max)    | -51dbm          | Perfect                |             |                              |
| 99          |                 | Unknown/not detectable | 99          | Unknown/not detectable       |

The GSM modem works normally with a minimum **<rss>** between 11 and 15.

Bellow 10, the signal level is insufficient; the modem cannot work depending on the geographical situation or the vehicle mobility. Above 15, the signal is sufficient.

For more information about AT commands, see the document "EG\_EGM\_CL\_xxx\_yy" of ERCO & GENER.

### 5.6 Verification of the PIN code

**The modem contains the EGM standard library (see the documents "EG\_EGM\_CL\_xxx\_yy" of ERCO & GENER) in this case, the PIN code is essential in order to make a call or to accept a response coming from the GSM network. This code is held in the SIM card and can be modified by the user.**

To check that the PIN code has been entered, use a communication software like Hyperterminal, and enter the command **AT+CPIN?**

The table below shows the main responses given by the modem:

| Command  | Response               | Interpretation                           |
|----------|------------------------|------------------------------------------|
| AT+CPIN? | <b>+CPIN : ERROR</b>   | The SIM card is absent or not recognized |
|          | <b>+CPIN : READY</b>   | The PIN code is correct                  |
|          | <b>+CPIN : SIM PIN</b> | The PIN code is wrong or not entered yet |
|          | <b>+CPIN : SIM PUK</b> | The PUK code is required                 |

For more information about AT commands, see the document "EG\_EGM\_CL\_xxx\_yy" of ERCO & GENER.

### 5.7 Verification of the modem registration on the GSM network

The modem contains the EGM standard library (see the documents "EG\_EGM\_CL\_xxx\_yy" of ERCO & GENER) in this case:

1. Ensure that a valid SIM card has been inserted in the SIM card reader of the modem.
2. Using a communications application like HyperTerminal, enter the following AT commands:
  - a. **AT+CPIN="xxxx"** to enter the PIN code. The user has only 3 attempts to enter the PIN code. After the third attempt, only a second code (code PUK) supplied by the operator, will allow you to chose a new PIN code.
  - b. **AT+CREG?** to check the registration status on the network. The response will be of the following format : **+CREG : <mode>, <stat>** with:
    - <Mode> = configuration of the registration message not solicited,
    - <Stat> = registration status.
3. Check the registration status according to the value returned in the table hereunder.

| Command  | Response                  | Interpretation                                        |
|----------|---------------------------|-------------------------------------------------------|
| AT+CREG? | <b>+CREG : 0,0</b>        | The modem is not recognized by the network            |
|          | <b>+CREG : 0,2 or 0,3</b> | The modem is searching for a network operator.        |
|          | <b>+CREG : 0,1</b>        | The modem is attached in GSM to the local operator.   |
|          | <b>+CREG : 0,5</b>        | The modem is attached in GSM to the roaming operator. |

If the modem is not registered: check the connection between the modem and the antenna or the reception level of the signal (cf. paragraph 5.5 Checking the quality of the GSM reception signal).

For more information about AT commands, see the document "EG\_EGM\_CL\_xxx\_yy" of ERCO & GENER.

### 5.8 Main AT commands (HAYES)

The modem contains the EGM standard library (see the documents "EG\_EGM\_CL\_xxx\_yy" of ERCO & GENER) in this case, the table below shows the main AT commands necessary for the control of the modem.

Other AT commands are available, see the document "EG\_EGM\_CL\_xxx\_yy" of ERCO & GENER.

Table: Main AT commands used with the modem.

| Description                                 | AT Command                                                                                                      | Response                  | Interpretation                                                          |
|---------------------------------------------|-----------------------------------------------------------------------------------------------------------------|---------------------------|-------------------------------------------------------------------------|
| Enter the PIN code                          | AT+CPIN="xxxx"<br><br>(xxxx = PIN code)                                                                         | <b>OK</b>                 | PIN code accepted                                                       |
|                                             |                                                                                                                 | <b>+CME ERROR: 16</b>     | PIN code incorrect (1*)                                                 |
|                                             |                                                                                                                 | <b>+CME ERROR: 3</b>      | PIN code already entered (1*)                                           |
| Verification of registration on the network | AT+CREG?                                                                                                        | <b>+CREG : 0,1</b>        | The modem is attached in GSM to the local operator.                     |
|                                             |                                                                                                                 | <b>+CREG : 0,5</b>        | The modem is attached in GSM to the roaming operator.                   |
|                                             |                                                                                                                 | <b>+CREG : 0,2</b>        | The modem is searching for a network operator.                          |
|                                             |                                                                                                                 | <b>+CREG : 0,0 or 0,3</b> | The modem is not recognized by the network.                             |
| Reception of an incoming call (2*)          | ATA                                                                                                             | <b>OK</b>                 | Reply to the call                                                       |
| Make a voice outgoing call                  | ATD<telephone number>;<br><br>( the ; at the end of the sequence is important; it allows to make a voice call ) | <b>OK</b>                 | Communication established                                               |
|                                             |                                                                                                                 | <b>+CME ERROR: 11</b>     | PIN code not entered                                                    |
|                                             |                                                                                                                 | <b>+CME ERROR: 3</b>      | The credit has run out or a communication has already been established. |
| Make an emergency call (112)                | ATD112;                                                                                                         | <b>OK</b>                 | Communication established                                               |
| Communication lost                          |                                                                                                                 | <b>NO CARRIER</b>         |                                                                         |
| Hang-up                                     | ATH                                                                                                             | <b>OK</b>                 |                                                                         |

(1\*) with **+CMEE=1**. The command **AT+CMEE=1** allows the display of extended error codes; it is possible to save it with the command **AT&W**.

By default, some event codes **+EGEVT** allow the display of status change of the SIM card (card present, card ready...) and allows to know some status of the modem (modem ready after a RESET ...), see the Command List of ERCO & GENER.

(2\*) with **+CRC=1**. The command **AT+CRC=1** allows in the case of an incoming call to display an extended message that indicates the canal called. This message corresponds to the type of number called: voice, data, it is possible to save it with the command **AT&W**.

Examples:

If the VOICE number is called, the modem replies: **+CRING : VOICE**

If the DATA number is called, the modem replies: **+CRING : REL ASYNC**

## 5.9 Turning off the modem

The modem contains the EGM standard library (see the documents "EG\_EGM\_CL\_xxx\_yy" of ERCO & GENER) in this case, it is strongly advised to un-register from the network with the command **AT+COPS=2**

---

For the battery, a mechanism allows to stop completely the application if the external power supply is unplugged, and also to prepare the modem for storage or transport, in order to limit high discharges of the battery.

If the device is not used, it has to be deactivated by sending the following command:

- **If the modem has an application developed with EGM, send the command **AT+GPIOSET=35,0****

And cut the external power supply of the modem.

- **If the modem does not contain any embedded application, via the Boot-Loader menu**

*Bootloader V2.39 GL53 UA GenPro 53e ENF (HW16 rev B/C)*

*GSM voltage = 4330 mV*

*1 - Update application*

*2 - Erase objects*

*M - GSM direct access*

*A - Advanced*

*P - Power off*

*E - Exit*



**Enter "P"**

And cut the external power supply of the modem.

**Important Note** : The switching of the battery and its auto-maintain will be automatically reactivated once the modem will be plugged to its external power supply.

---

## 5.10 Modem updating procedure

To be able to benefit from the latest functions of the [GenPro 53e](#), an updating procedure can be used to upgrade the software program in the modem.

This procedure consists in downloading the software into the internal Flash memory of the modem via the RS232 link available on the 9-pin Sub 9 connector.

Contact us for the software updating.

## 6 Trouble Shooting

This section of the document describes the problems that may be encountered when using the modem.

### 6.1 Problem of communication between the modem and the RS232 link (V24)

If the modem does not respond to the AT commands via the RS232 link, refer to the table below to see the possible causes and the solutions.

Table: Solutions when there is no dialogue between the modem and the RS232 link

| If the modem...                      | Check:                                                                                              | Action                                                                                                                                                                                                                                                                                                                                                                                                                                                                                                       |
|--------------------------------------|-----------------------------------------------------------------------------------------------------|--------------------------------------------------------------------------------------------------------------------------------------------------------------------------------------------------------------------------------------------------------------------------------------------------------------------------------------------------------------------------------------------------------------------------------------------------------------------------------------------------------------|
| Returns nothing                      | Is the modem correctly powered?                                                                     | Ensure that the modem is connected to an external regulated power source and supplies a tension from 5.5V to 32V (see paragraph 8.2.1 Power supply).                                                                                                                                                                                                                                                                                                                                                         |
|                                      | Is the serial cable connected at both ends (PC and Modem)?                                          | Check the connection of the serial cable.                                                                                                                                                                                                                                                                                                                                                                                                                                                                    |
|                                      | Is the serial cable correctly cabled according to the paragraph 3.2.2.3 16-wire micro FIT cable     | Connect the serial cable according to the table of paragraph 3.2.1.2 Micro FIT connectors.                                                                                                                                                                                                                                                                                                                                                                                                                   |
| Returns nothing or random characters | Is the communications terminal correctly configured on the PC?                                      | Ensure that the configuration of the communication terminal corresponds with the one of the modem.<br>Factory configuration of the modem :<br>Without application (BootLoader), standard library or <a href="#">EasePro_Vx application</a><br>speed = 115 200 bps<br>Data Bits = 8<br>Parity = none<br>Stop Bits = 1<br>Flow control = material<br><del>Application EasePro-01</del><br><del>Contact us.</del><br>Owner application<br>speed , data bits , parity and stop bits according to your parameters |
|                                      | Is there another application used, creating a conflict during the access to the communication port? | Close the conflicting application.                                                                                                                                                                                                                                                                                                                                                                                                                                                                           |
|                                      | Is the modem without echo and without message reporting?                                            | Send the command <b>ATE1Q0</b> followed by <b>AT&amp;W</b> if a backup is required .                                                                                                                                                                                                                                                                                                                                                                                                                         |

\* only if the GenPro 53e has [EasePro\\_Vx](#) application

## 6.2 "ERROR" message



This paragraph is valid only if the modem contains the EGM standard library or the [EasePro\\_Vx](#) application.

The modem returns a message "**ERROR**" (in response to an AT command) in the following cases:

- The COM port is not directed to the modem [GenPro 53e](#) but to another modem. Enter **AT11**, and the response must be **Enabler\_III...** Any other response indicates a dialog with another modem. In this case, check the COM port used in the Hyperterminal.
- The syntax of the AT command is incorrect: check it (see the document "EG\_EGM\_CL\_xxx\_yy" of ERCO & GENER"
- The syntax of the AT command is correct, but transmitted with wrong parameters:
  - Enter the command **AT+CMEE=1** to obtain an error message with its error code instead of a simple "ERROR" message,
  - Enter again the AT command which previously caused the "ERROR" message in order to obtain the error code.

In case of an error code, the response of the modem may be:

+CME ERROR : < error code >

For more information about the error codes returned after having sent the command **AT+CMEE**, see the document "EG\_EGMCL\_xxx\_yy" of ERCO & GENER.



It is strongly recommended to systematically allow the modem to return the error codes (enter the command **AT+CMEE=1**).

## 6.3 "NO CARRIER" message



This paragraph is valid only if the modem contains the EGM standard library or the [EasePro\\_Vx](#) application.

If the modem returns the message "NO CARRIER" after an attempted call (voice or data), check the table below to see the possible causes and the solutions.

Table: Solutions when a message "NO CARRIER" is returned

| If the modem...                             | Check :                                                                                       | Action                                                                                                                                                       |
|---------------------------------------------|-----------------------------------------------------------------------------------------------|--------------------------------------------------------------------------------------------------------------------------------------------------------------|
| "NO CARRIER"                                | Is the received GSM signal strong enough?                                                     | See the paragraph 5.5 to check the quality of the received signal .                                                                                          |
|                                             | Is the modem registered on the network?                                                       | See the paragraph 5.7 to check the registration of the modem on the GSM network                                                                              |
|                                             | Is the antenna correctly connected?                                                           | See the paragraph 8.2.8.2 GSM external antenna for the recommendations about the GSM antenna installation .                                                  |
| "NO CARRIER" (when attempting a VOICE call) | Has the semi-colon (;) been entered immediately after the telephone number in the AT command? | Ensure that the semi-colon (;) has been entered immediately after the telephone number in the AT command.<br>For example : ATD0123456789;                    |
| "NO CARRIER" (when attempting a DATA call)  | Has the SIM card been configured for data?                                                    | Ensure that the SIM card is allowed to make data calls (check with your SIM card supplier).                                                                  |
|                                             | Is the selected modulation type supported by the called number?                               | Ensure that the selected modulation type is supported by the called number.                                                                                  |
|                                             | Is the selected modulation type supported by the network?                                     | Ensure that the selected modulation type is supported by the network. If not, select a compatible modulation type with the command <i>AT+CBST=0,0,1</i> (1*) |

(1\*) For more information about this AT command, see the document "EG\_EGM\_CL\_xxx\_yy" of ERCO & GENER.

If the modem returns the message "NO CARRIER", you can get the extended error code with the command **AT+CEER**.

For more information about the error codes returned after having sent the command **AT+CEER**, see the document "EG\_EGM\_CL\_xxx\_yy" of ERCO & GENER.

## 7 Functional Description

### 7.1 Architecture

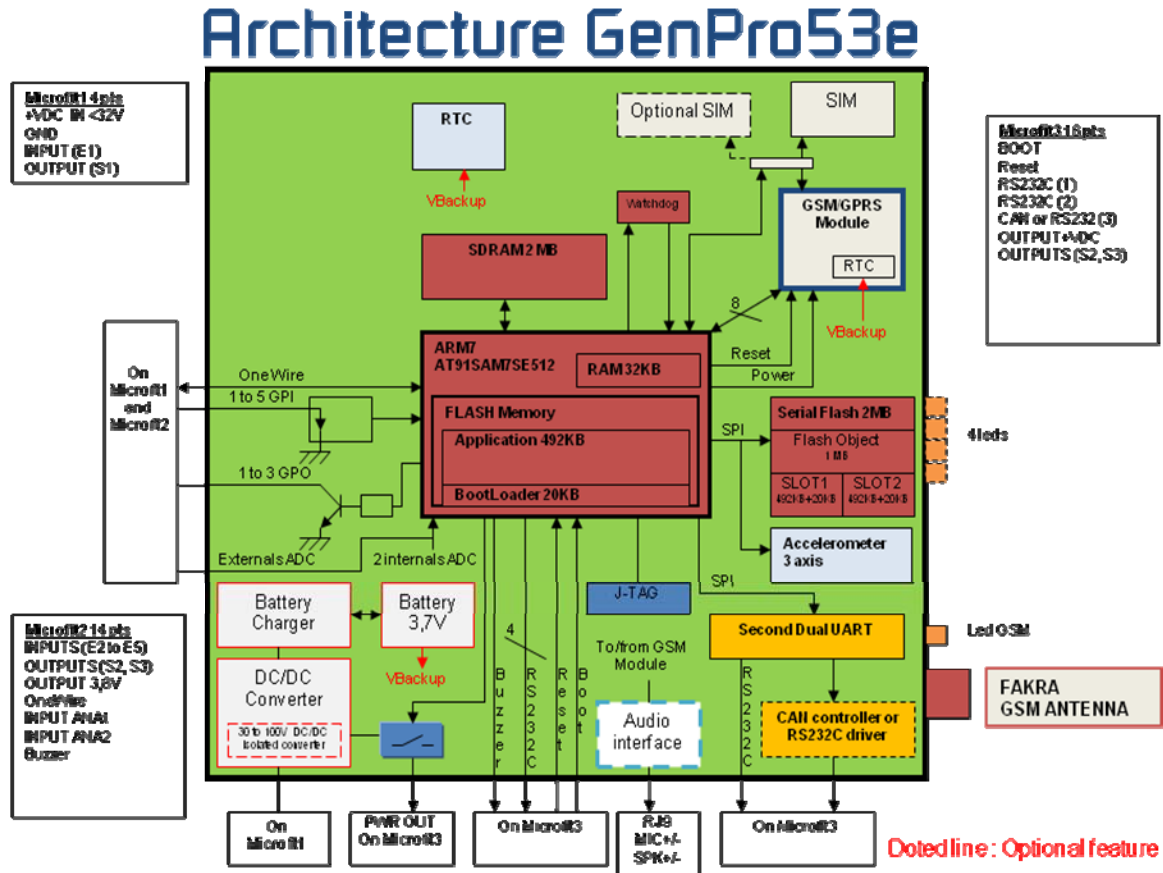

### 7.2 Power supply

#### 7.2.1 General presentation

The modem must be powered by an external DC tension (V+BATTERY) between +5.5V and +32V.

The regulation of the modem power supply is made with a DC/DC internal converter in order to supply all the necessary internal DC tensions.



A correct functioning of the modem in communication cannot be guaranteed if the input tension (V+BATTERY) falls below 5.5 V and if the battery is not charged enough.



## 7.2.2 Internal battery

### 7.2.2.1 Presentation of the internal battery

The battery is fixed inside the [GenPro 53e](#). It is connected to an additional charging circuit cabled on the mother board of the [GenPro 53e](#).

This battery allows to maintain the [GenPro 53e](#) functioning in the absence of its external power supply (power supply connected on the Micro-FIT 4-pin female connector).

The internal charging circuit allows to keep permanently the charge of the battery from the external power supply.

When the battery is completely discharged, 3 hours are necessary to obtain a new complete charge. It is normal that the box gently heated in this case.

The autonomy of the battery essentially depends on the mode of use of the [GenPro 53e](#) (attachment in GSM/GPRS, Inputs/Outputs, RS232 connected...).



When the temperature exceeds 45 °C inside the box, the protection of the battery management triggers. The battery will not be charged.



If the battery is present, prepare the modem for storage or transport conditions, in order to limit high discharges of the battery. For that, see § 5.9 Turning off the modem

### 7.2.2.2 Specifications of the internal battery

The external power supply of the [GenPro 53e](#) remains unchanged (from +5,5V to 32V DC). The internal regulator of charge supplies the 4.2V tension necessary for the battery charge.

Table: Characteristics of the polymer lithium battery

|                             |                                                                                      |                            |
|-----------------------------|--------------------------------------------------------------------------------------|----------------------------|
| Tension (max.)              | 4.2V                                                                                 |                            |
| Type                        | Lithium Polymère (LiPolymère)                                                        |                            |
| Capacity                    | 1000 mA/h typical                                                                    |                            |
| Exp. Cycle time             | >300 cycles > 70% of initial capacity                                                |                            |
| Temperature range           | Charge : 0°C to +45°C                                                                | Discharge : -20°C to +60°C |
| Protection (Rearmable fuse) | Discharge voltage : 2.30V ±0.058V<br>Maximum discharge current : 2A to 4A (1.0±0.3s) |                            |

### 7.2.2.3 Charge voltage and supply voltage

See paragraph 8.2.1.2 Consumption of the board with battery

7.2.2.4 Indication of presence/absence of the external power supply

The modem contains the EGM standard library (see the documents "EG\_EGM\_CL\_xxx\_yy" of ERCO & GENER) in this case, the command **AT+GPIOGET=27** allows to know the status of the external power supply for the internal battery.

**AT+GPIOGET=27**

<Index>

- 0 indication of absence of external power supply
- 1 indication of presence of external power supply

Table: Examples of responses with the internal battery option cabled

| Command       | Response                       | Interpretation          |
|---------------|--------------------------------|-------------------------|
| AT+GPIOGET=?  | <b>+GPIOGET: (0-27)<br/>OK</b> | Syntax                  |
| AT+GPIOGET=27 | <b>+GPIOGET: 27=0<br/>OK</b>   | External supply present |
| AT+GPIOGET=27 | <b>+GPIOGET: 27=1<br/>OK</b>   | External supply absent  |

For more information concerning this command, see the document EG\_EGM\_CL\_xxx\_yy of ERCO & GENER.

7.2.2.5 Instructions and restrictions of use

When the battery is completely discharged, it takes around three hours to obtain a complete charge.  
 When the battery is connected and charged, it is not possible to do an On/Off of the device, only putting the Reset input (pin 10 of the 16-pin micro-FIT connector) to the ground or sending the command **AT+EGMRST** allows a reset of the modem.



The battery cannot be replaced or modified by the user; the device must not be opened for any intervention on the battery; the device must be returned to the factory.

Do not throw the modem and the battery on the fire.

### 7.2.3 Protections of the power supply

The modem is protected by a F2 A / 32 V fuse directly assembled on the power supply cable supplied with the modem.



Fuse reference: Mini Blade car 2A - 32V (code couleur : grey)

The modem is also internally protected against tension peaks of more than 32 V.

Filter guarantees: EMI/RFI protection in input and output and signal smoothing.



It is necessary to use the supply cable delivered with the modem, otherwise the modem will not be protected.

## 7.3 RS232 serial link

### 7.3.1 General Presentation

The RS232 interface provides an adaptation of the tension levels (V24/CMOS  $\Leftrightarrow$  V24/V28) between the GSM/GPRS module (DCE) and the communication port of a PC (DTE).

The RS232 interface is internally protected (ESD protection) against electrostatic peaks coming from the RS232.

Filter guarantees: EMI/RFI protection in input and output and signal smoothing.

The RS232 interface was designed to allow a certain flexibility in the use of the serial interface signals.

In fact, after the setting (see command **AT+IFC**) if the [GenPro 53e](#) contains the EGM standard library (see the documents "EG\_EGM\_CL\_xxx\_yy" of ERCO & GENER) in this case, the modem can work in 3-wire mode (using only the signals TX, RX, GND), but the use of the signals TX, RX, GND, CTS, RTS is required for a GPRS application.

### 7.3.2 Serial link RS232\_0

The signals of the RS232\_0 are available on the 16-pin Micro FIT connector and on the 9-pin Sub D connector. (see chapter 3.2.2.3 16-wire micro FIT cable)

TX data (CT103/TX\_0) : Data emission,

RX data (CT104/RX\_0) : Data reception,

Request To Send (CT105/RTS\_0) : Request to send,

Clear To Send (CT106/CTS\_0) : Ready to send.

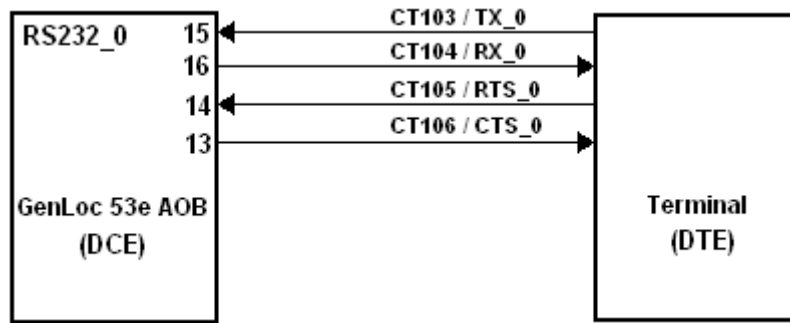

Normalized signals of a RS232\_0 serial link

Pins description

| Signal        | 16-pin micro FIT connector<br>Pins number | I/O | RS232 standard | Description          | Sub D 9-pin connector<br>Pins number |
|---------------|-------------------------------------------|-----|----------------|----------------------|--------------------------------------|
| CT103 / TX_0  | 15                                        | I   | TX             | Transmit serial data | 3                                    |
| CT104 / RX_0  | 16                                        | O   | RX             | Receive serial data  | 2                                    |
| CT105 / RTS_0 | 14                                        | I   | RTS            | Request To Send      | 7                                    |
| CT106 / CTS_0 | 13                                        | O   | CTS            | Clear To Send        | 8                                    |
| GND           | 12                                        |     |                | Ground               | 5                                    |

7.3.3 Serial link RS232\_1

The signals of the RS232\_1 are available on the Micro FIT 16-pin connector and on the cable. (see chapter 3.2.2.3 16-wire micro FIT cable )

- TX data (CT103/TX\_1) : Data emission,
- RX data (CT104/RX\_1) : Data reception,
- Request To Send (CT105/RTS\_1) : Request to send,
- Clear To Send (CT106/CTS\_1) : Ready to send.

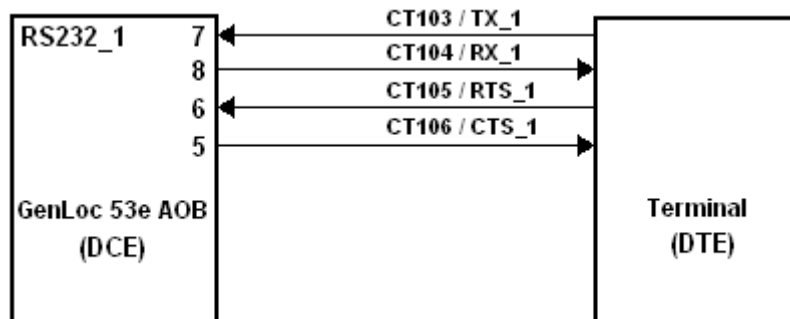

Normalized signals of a RS232\_1 serial link

Pins description

| Signal        | Micro FIT 16-pin connector Pins number | I/O | RS232 standard | Description          | Color of wire |
|---------------|----------------------------------------|-----|----------------|----------------------|---------------|
| CT103 / TX_1  | 7                                      | I   | TX             | Transmit serial data | White/Green   |
| CT104 / RX_1  | 8                                      | O   | RX             | Receive serial data  | White /Blue   |
| CT105 / RTS_1 | 6                                      | I   | RTS            | Request To Send      | White /Yellow |
| CT106 / CTS_1 | 5                                      | O   | CTS            | Clear To Send        | White /Brown  |
| GND           | 4                                      |     |                | Ground               | Black         |

### 7.3.4 Serial link RS232\_2 / Bus CAN

As an option, it is possible to have a third serial link (contact us).

It can be on the RS232 standard or CAN standard.

#### 7.3.4.1 RS232\_2

The signals of the RS232\_2 are available on the 16-pin Micro FIT connector and on the cable. (see chapter 3.2.2.1 16-wire micro FIT cable)

TX data (CT103/TX\_2) : Data emission,

RX data (CT104/RX\_2) : Data reception.

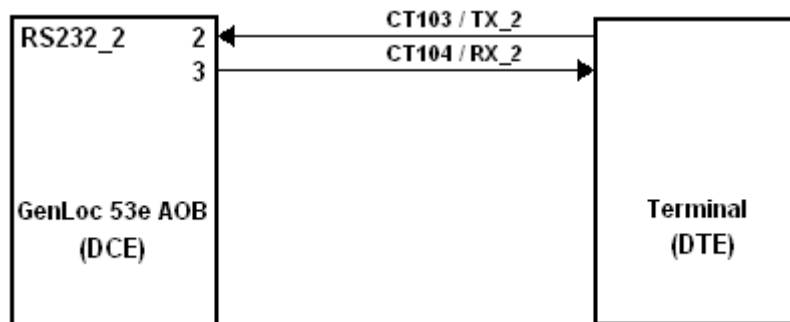

Normalized signals of a RS232\_2 serial link

Pins description

| Signal       | Micro FIT 16-pin connector Pins number | I/O | RS232 standard | Description          | Color of wire |
|--------------|----------------------------------------|-----|----------------|----------------------|---------------|
| CT103 / TX_2 | 2                                      | I   | TX             | Transmit serial data | Violet        |
| CT104 / RX_2 | 3                                      | O   | RX             | Receive serial data  | White/Violet  |
| GND          | 1                                      |     |                | Ground               | Black         |

7.3.4.2 Bus CAN

The signals of the bus CAN are available on the Micro FIT 16-pin connector and on the cable. (see chapter 3.2.2.3 16-wire micro FIT cable )

The data transmission is done on a differential wire pair. The line is then made with 2 wires,

- CANH : Positive differential line,
- CANL : Negative differential line.

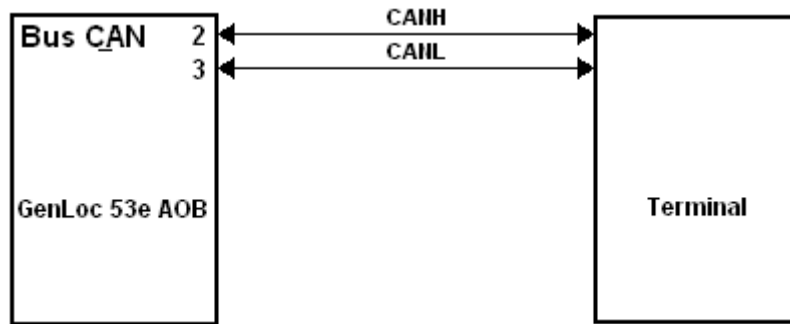

Normalized signals of a serial link CAN

Pins description

| Signal | Micro FIT 16-pin connector Pins number | I/O | Standard CAN | Description                | Color of wire |
|--------|----------------------------------------|-----|--------------|----------------------------|---------------|
| CANH   | 2                                      | I/O | CAN High     | Positive differential line | Violet        |
| CANL   | 3                                      | I/O | CAN Low      | Negative differential line | White/Violet  |
| GND    | 1                                      |     |              | Ground                     | Black         |

7.4 Inputs/Output functioning

The GenPro 53e provides five Inputs (opto-coupled), three Outputs (open collector) and two analog Inputs available for an external use.

As an option (contact us) the inputs E3 and E5 can be insulated.

The modem contains the EGM standard library (see the documents "EG\_EGM\_CL\_xxx\_yy" of ERCO & GENER) in this case, these functions can also be controlled by AT commands:

- AT+GPIOSET** for a writing access to a GPIO used as an output,
- AT+GPIOGET** for a reading access to the GPIO used as an input.
- AT+ xxxx** for a reading access of the GPIO used as an analog input. Contact us.

### 7.4.1 Management of logical outputs

The modem contains the EGM standard library (see the documents "EG\_EGM\_CL\_xxx\_yy" of ERCO & GENER) in this case, these functions are controlled by AT commands.

**AT+GPIOSET** This command is used to drive the output. By default, the output S1 to S3 are cabled as an open collector assembly. To control it:

**AT+GPIOSET=<n>,<x>** with :

- <n> = 10 : writing of output S1
- 18 : writing of output S2
- 19 : writing of output S3
- <x> = 0 : Output OFF
- 1 : Output ON

Examples:

| Command         | Response                           | Interpretation                        |
|-----------------|------------------------------------|---------------------------------------|
| AT+GPIOSET=10   | <b>+GPIOSET: 10=1</b><br><b>OK</b> | Output 1 OFF, transistor closed       |
| AT+GPIOSET=10,0 | <b>OK</b>                          | Output 1 goes to ON (transistor open) |



See table of the paragraph 8.2.3.2 Output for the characteristics of use of the Inputs/Output

### 7.4.2 Management of logical inputs

The modem contains the EGM standard library (see the documents "EG\_EGM\_CL\_xxx\_yy" of ERCO & GENER) and in this case, these functions are controlled by AT commands.

**AT+GPIOGET** This command is used to read the inputs. By default, the inputs 1 to 5 are opto-coupled. To read:

**AT+GPIOGET=<n>** with :

- <n> = 7 : reading the input E1
- 8 : reading the input E2
- 9 : reading the input E3
- 36 : reading the input E4
- 37 : reading the input E5

Examples:

| Command      | Response                           | Interpretation                                  |
|--------------|------------------------------------|-------------------------------------------------|
| AT+GPIOGET=7 | <b>+GPIOGET: 7= 1</b><br><b>OK</b> | Input 1 read at 1, the input 1 is not commanded |
| AT+GPIOGET=9 | <b>+GPIOGET: 9= 0</b><br><b>OK</b> | Input 3 read at 0, the input 3 is commanded     |



See table of the paragraph 8.2.3.1 Opto-coupled inputs for the characteristics of use of the Inputs/Output

### 7.4.3 Management of analog inputs

The commands for the management of analog inputs are currently under development. Contact us.



See table of the paragraph 8.2.3.3 Analog input for the characteristics of use of the Inputs/Output

## 7.5 Option 2<sup>nd</sup> SIM card reader

Contact us.

## 7.6 BOOT



This signal must NOT be connected, NOT used. Its use is strictly reserved for the manufacturer.



The use of the BOOT function is strictly reserved to the manufacturers and distributors

## 7.7 RESET

### 7.7.1 General presentation

This signal allows to make a Hardware RESET of the modem. In fact, this pin is used to force a RESET of the [GenPro 53e](#), doing a low level during at least 10 ms.

This signal must be used only in case of emergency RESET.

This signal must be driven with an open collector assembly:

- pin 10 (RESET) at 0, to Reset the [GenPro 53e](#),
- pin 10 (RESET) at 1, for normal mode.



Pin description

| Signal | 14-pin connector Pins number | I/O | Type I/O | Description |
|--------|------------------------------|-----|----------|-------------|
| RESET  | 10                           | I/O | SCHMITT  | Reset Modem |



The use of the RESET function is strictly reserved to the manufacturers and distributors.



This signal must be used only in case of emergency RESET. A software RESET is always preferable to a Hardware RESET. It is strongly unadvised to execute this function whilst in communication or dialog, without having previously detached it from the network. Using the RESET does not restore the factory parameters.



For more information concerning the Software RESET, see the document "EG\_EGM\_CL\_xxx\_yy" of ERCO & GENER and refer to paragraph 5.10 to turn the device off and detach correctly the modem from the network operator.



See the table of paragraph 8.2.6 RESET Signal for the characteristics of use of the RESET

7.7.2 RESET Sequence

To activate the emergency RESET sequence, the RESET signal must be put to a low level during at least 10 ms.

As soon as the modem has been RESET, if a SIM card is inserted inside the SIM reader, you must wait for the end of the initialization before accessing it again.

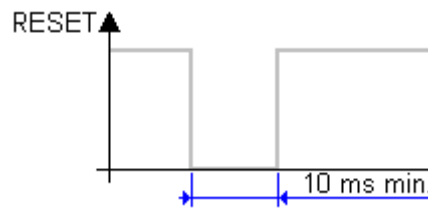

Using the RESET does not restore the factory parameters.

## 7.8 WatchDog

The Hardware WatchDog function allows the surveillance of the [GenPro 53e](#) software activity: the Software management of the WatchDog is implanted in the embedded application by default. In the case of a development (EGM) it must be implanted in the embedded application of the final customer.

If the software activity is interrupted, the WatchDog component starts a hardware Reset.



The WatchDog function is active only if the SIM card is present. That's why, it is imperative to remove the SIM card during a Firmware updating.

## 7.9 Audio

The audio interface is standard to connect an equipment like a telephone handset.

The modem contains the EGM standard library (see the documents "EG\_EGM\_CL\_xxx\_yy" of ERCO & GENER) in this case, the echo cancelation (see command **AT\$MICAEC**) and noise reduction features are also available to improve the audio quality in the case of free-hand applications. The command **AT\$VSELECT** also allows the Handset selection.

(see paragraph 3.2.1.3 Audio connector ).

|           | RJ9 |
|-----------|-----|
| Micro -   | 1   |
| Speaker - | 2   |
| Speaker + | 3   |
| Micro +   | 4   |

### 7.9.1 Microphone inputs

The microphone inputs are assembled in differential to reduce the noise in common mode and the TDMA noise.

They include the functionality for a microphone like Electret (0.5 mA and 2 Volts) and they are ESD protected. This Electret microphone can be directly connected to these inputs allowing an easy connection to a telephone handset.

The microphone impedance is around 36 kΩ.

The gain of the microphone inputs is internally adjusted by a differential amplifier and can be adjusted, if the modem contains the EGM standard library (see the documents "EG\_EGM\_CL\_xxx\_yy" of ERCO & GENER) using the command **AT+PREAM**. The amplifier has a gain of 25.6 dB and a Bias generator that supplies an external tension of 2 or 2.5V for the microphone Bias.

Pin description

| Signal | RJ9 connector<br>Pins number | I/O | I/O Type | Description                      |
|--------|------------------------------|-----|----------|----------------------------------|
| MIC2P  | 4                            | I   | Analog   | Positive input of the Microphone |
| MIC2N  | 1                            | I   | Analog   | Negative input of the Microphone |

### 7.9.2 Loud-speaker outputs (Speaker)

The outputs are assembled in differential to reduce the noise in common mode and the TDMA noise.

These outputs can be directly connected to a loudspeaker.

Pin description

| Signal | RJ9 connector<br>Pins number | I/O | I/O Type | Description                    |
|--------|------------------------------|-----|----------|--------------------------------|
| SPK2P  | 3                            | O   | Analog   | Positive output of loudspeaker |
| SPK2N  | 2                            | O   | Analog   | Negative output of loudspeaker |

Recommended characteristics for the loudspeaker

### 7.9.3 Buzzer outputs

By default, the [GenPro 53e](#) provides a Buzzer output on the output 14 of the 14-pin connector. This output provides a frequency, it is dedicated to drive a **Transducer**.

Pin description

| Signal | 14 pins connector<br>Pins number | I/O | I/O Type | Description   |
|--------|----------------------------------|-----|----------|---------------|
| BUZZER | 14                               | O   | Analog   | Output Buzzer |

## 7.10 Accelerometer

The [GenPro 53e](#) provides an accelerometer with 3 axis of sensitivity  $\pm 2G$  or  $\pm 8G$  controllable by software.

Positioning of the axis

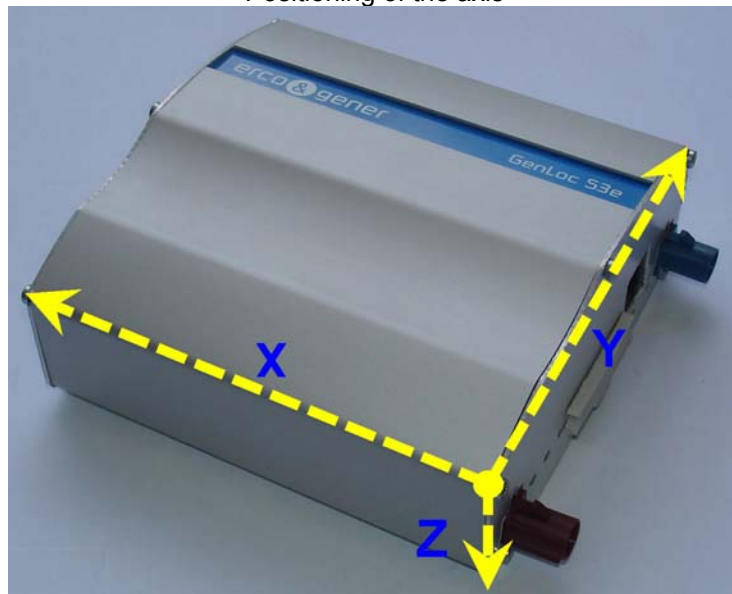

## 7.11 Internal processor

### 7.11.1 EGM presentation

The [GenPro 53e](#) provides an ARM7 processor that allows to have an embedded application developed from the EGM libraries and based on eCos.

The EGM libraries supplied by ERCO & GENER contain the following elements:

- EGM software library,
- eCos software library,
- A set of header files (.h) defining the EGM API functions,
- Source code samples.

7.12.2 EGM architecture

The software architecture is described below.

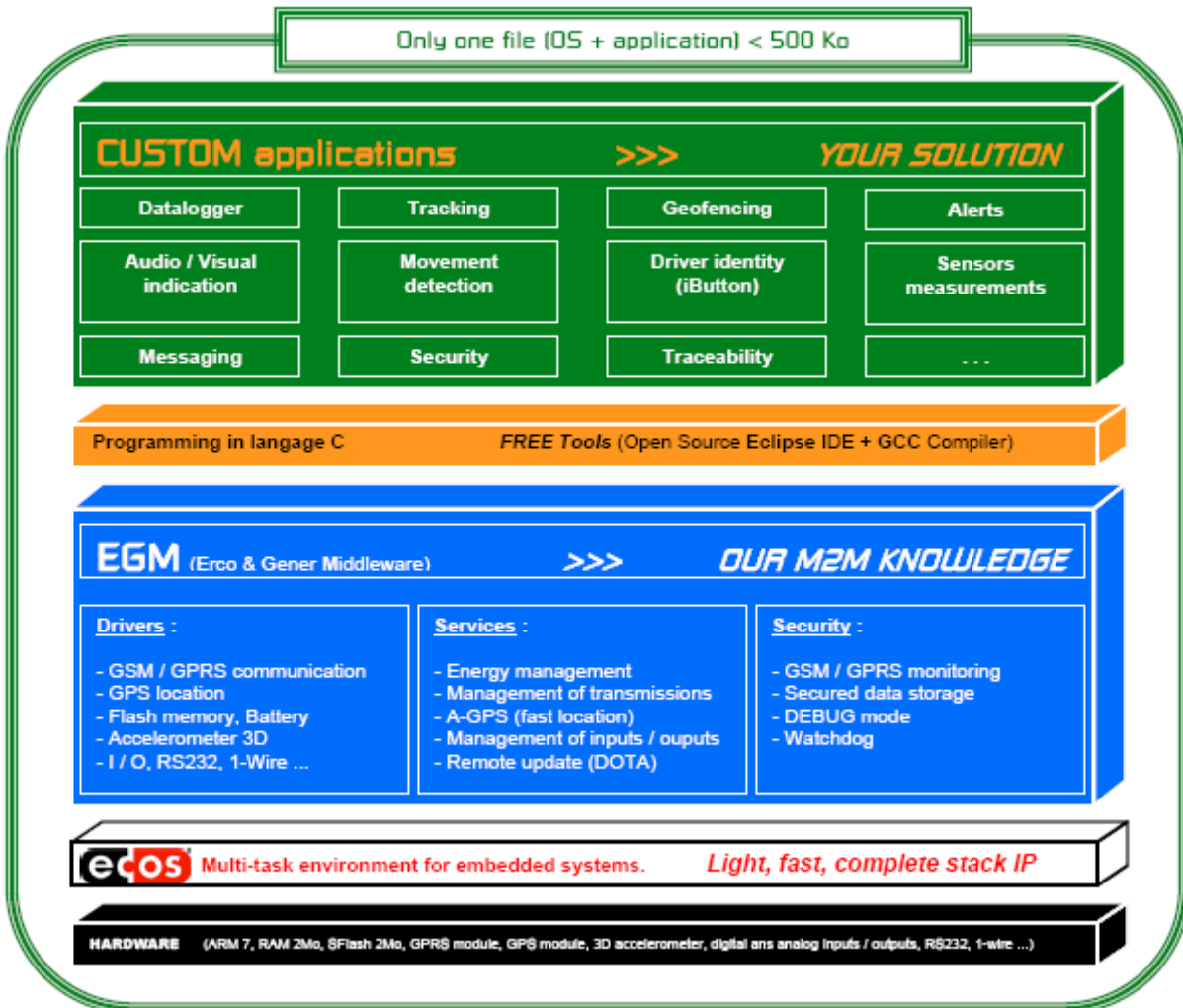

For more information about EGM, see the documents ERCO & GENER for a description of the different functionalities.

## 8 Technical characteristics

### 8.1 Mechanical characteristics

|                     |                                                                     |
|---------------------|---------------------------------------------------------------------|
| Dimensions          | 95 x 92 x 40 mm ( excluding the connectors )                        |
| Complete dimensions | 104 x 92 x 40 mm                                                    |
| Weight              | ≈ 206 grams (modem only)<br>< 618 grams (modem + brackets + cables) |
| Volume              | ≈ 382 cm <sup>3</sup>                                               |
| Casing              | Aluminum profile                                                    |
| Waterproof level    | IP31                                                                |

The illustration below shows the dimensions of the modem including the clearances necessary for the installation of the modem.

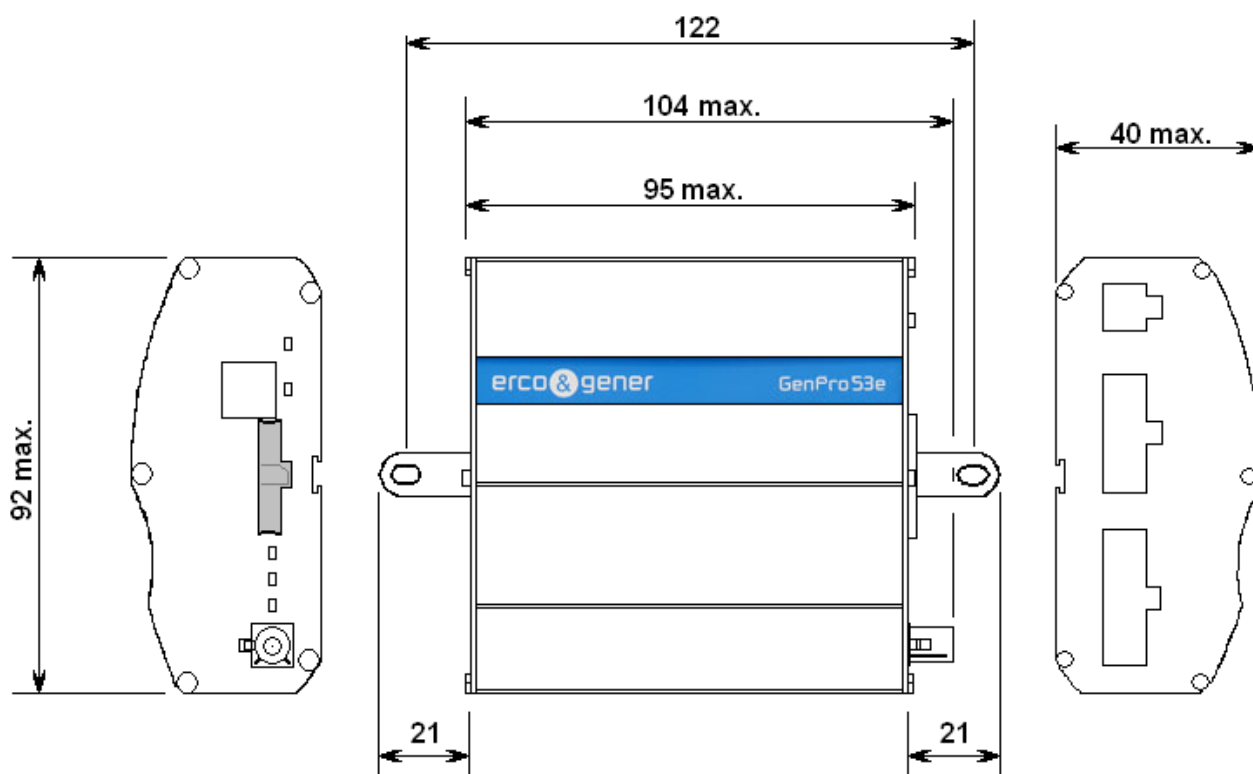

## 8.2 Electrical characteristics

### 8.2.1 Power supply

Table: Electrical characteristics

|                            |                              |                                                                                                                                 |
|----------------------------|------------------------------|---------------------------------------------------------------------------------------------------------------------------------|
| <b>Power supply range</b>  |                              | 5.5V to 32V DC                                                                                                                  |
| <b>Average consumption</b> | <b>Conditions</b>            |                                                                                                                                 |
|                            | Battery charged<br>GSM OFF   | 28 mA @ 12V                                                                                                                     |
|                            | Battery in charge<br>GSM OFF | 151 mA @ 12V                                                                                                                    |
|                            | Battery charged<br>GSM ON    | - 900 MHz.....: 145 mA @ 12V in communication<br>- 1800 MHz.....: 131 mA @ 12V in communication<br>- Mode repos...: 30 mA @ 12V |



Once the power supply is connected, the modem is permanently consuming.



If the battery is present, prepare the modem for storage or transport conditions, in order to limit high discharges of the battery. For that, see § 5.9 Turning off the modem

The following table describes the consequences of over-voltage or insufficient voltage on the modem.

Table: Effects of a power supply defect

|                                                | Then:                                                                                                          |
|------------------------------------------------|----------------------------------------------------------------------------------------------------------------|
| ▪ Voltage falls below 5.5V                     | ▪ The functioning and the GSM are not guaranteed when the remaining capacity of the battery is not sufficient. |
| ▪ Voltage above 32V (Punctual peaks )          | ▪ The modem guarantees its own protection.                                                                     |
| ▪ Voltage above 32V (Continuous over-voltage ) | ▪ The modem is protected by the fuse mounted on the supply cable.                                              |



The modem does not have any internal protection. For that, you must use the supply cable provided with the modem which has this protection.

The following tables show the modem consumptions depending on the different functions activated.

For example:

The equipment is supplied with 12V with

- the battery charged
- RS 232 connected
- The GSM module in GPRS communication at 900 MHz

|                | I Nom.(mA)   | I Pic.(mA) |
|----------------|--------------|------------|
| <b>Board</b>   | 28           |            |
| <b>RS</b>      | 3.2          |            |
| <b>GSM</b>     | 191.3        | 804        |
| <b>Total :</b> | <b>222.5</b> | <b>804</b> |

The average consumption is 222.5 mA and the power supply must support current peaks of 804 mA.

The equipment is supplied with 12V with

- The battery charging
- RS 232 connected
- The GSM module in GPRS communication at 900 MHz

|                | I Nom.(mA)   | I Pic.(mA) |
|----------------|--------------|------------|
| <b>Board</b>   | 28           |            |
| <b>Battery</b> | 122.6        |            |
| <b>RS</b>      | 3.2          |            |
| <b>GSM</b>     | 191.3        | 804        |
| <b>Total :</b> | <b>345.1</b> | <b>804</b> |

The average consumption is 345.1 mA and the power supply must support current peaks of 804 mA.

### 8.2.1.1 Consumption of the board with battery charged

Table: Consumption of the board with battery charged

| CONDITIONS<br>T=25°C                              | +VDC   | I Nom.(mA) |
|---------------------------------------------------|--------|------------|
| Battery charged<br>GSM OFF<br>RS 232 disconnected | @ 5,5V | 50         |
|                                                   | @ 12V  | 28         |
|                                                   | @ 24V  | 17         |
|                                                   | @ 32V  | 14         |

(1\*) The consumptions of the power supply may vary by 5% depending on the temperature range (-20 °C to +55 °C).

### 8.2.1.2 Consumption of the board with battery charging

Table: Consumption of the board with battery charging

| CONDITIONS<br>T=25°C                               | +VDC   | I Nom.(mA) |
|----------------------------------------------------|--------|------------|
| Battery charging<br>GSM OFF<br>RS 232 disconnected | @ 5,5V | 295        |
|                                                    | @ 12V  | 151        |
|                                                    | @ 24V  | 84         |
|                                                    | @ 32V  | 66         |

(1\*) The consumptions of the power supply may vary by 5% depending on the temperature range (-20 °C to +55 °C).



8.2.1.3 Consumption of the RS 232

Table: Consumption of the RS 232 connection

| CONDITIONS<br>T=25°C                              | +VDC   | I Nom.(mA) |
|---------------------------------------------------|--------|------------|
| Battery charged<br>GSM OFF<br>RS 232 disconnected | @ 5,5V | 5.4        |
|                                                   | @ 12V  | 3.2        |
|                                                   | @ 24V  | 1.9        |
|                                                   | @ 32V  | 1.6        |

(1\*) The consumptions of the power supply may vary by 5% depending on the temperature range (-20 °C to +55 °C).



Typical value with a portable computer. The consumption may vary with other kinds of equipment

8.2.1.4 Consumption of the GSM module

Table: Consumption of the GSM module

Battery charged and RS232 disconnected

| CONDITIONS<br>T=25°C and SIM card 3V                              | +VDC   | 850 MHz    | 900 MHz    | 1800 MHz   | 1900 MHz   |
|-------------------------------------------------------------------|--------|------------|------------|------------|------------|
|                                                                   |        | I Nom.(mA) | I Nom.(mA) | I Nom.(mA) | I Nom.(mA) |
| Idle mode (2*)                                                    | @ 5,5V | 52         | 52         | 52         | 52         |
|                                                                   | @ 12V  | 30         | 30         | 30         | 30         |
|                                                                   | @ 24V  | 17         | 17         | 17         | 17         |
|                                                                   | @ 32V  | 14         | 14         | 14         | 14         |
| In GSM communication<br>1RX/1TX, Full Power<br>Power (2W/1W)      | @ 5,5V | 283        | 281        | 250        | 239        |
|                                                                   | @ 12V  | 146        | 145        | 131        | 126        |
|                                                                   | @ 24V  | 81         | 81         | 74         | 71         |
|                                                                   | @ 32V  | 64         | 63         | 58         | 56         |
| In GPRS CL10communication<br>2RX/2TX, Full Power<br>Power (2W/1W) | @ 5,5V | 453        | 455        | 385        | 371        |
|                                                                   | @ 12V  | 218        | 219        | 190        | 184        |
|                                                                   | @ 24V  | 117        | 117        | 104        | 101        |
|                                                                   | @ 32V  | 93         | 93         | 81         | 79         |
| During TX bursts<br>Power (2W/1W)                                 | @ 5,5V | 2 020      | 2 020      | 1 573      | 1 428      |
|                                                                   | @ 12V  | 832        | 832        | 658        | 601        |
|                                                                   | @ 24V  | 387        | 387        | 302        | 277        |
|                                                                   | @ 32V  | 309        | 309        | 256        | 238        |

(1\*) The consumptions of the power supply may vary by 5% depending on the temperature range (-20 °C to +55 °C).

(2\*) Idle mode = modem registered on network but out of communication.

**8.2.2 Audio interface**

The audio interface is available via the RJ 9 4/4 connector, (see paragraph 7.9.1 Microphone inputs, 7.9.2 Loud-speaker outputs (Speaker)) and pin 14 of the 14-pin connector for the Buzzer (see paragraph 7.9.3 Buzzer outputs ).

**8.2.2.1 Microphone**

Polarization characteristics for a Microphone HANDSET

| Polarization output  | Parameter/Conditions | Min | Typ | Max | Units |
|----------------------|----------------------|-----|-----|-----|-------|
| Polarization tension | Set to 2.0 V         | 1.9 |     | 2.1 | V     |
|                      | Set to 2.5 V         | 2.4 |     | 2.6 | V     |
| Polarization current |                      |     |     | 2.0 | mA    |

Recommended characteristics for the Microphone

| Input micro                                      | Parameters /Conditions                                                  | Min | Typ  | Max  | Units             |
|--------------------------------------------------|-------------------------------------------------------------------------|-----|------|------|-------------------|
| Maximum Input Range – Mic(+) to Mic(-)           | Inputs 3 dBm0 (Max. digital sample amplitude when PGA gain set to 0 dB) |     |      | 32.5 | mV <sub>RMS</sub> |
| Nominal Ref. Level – Mic(+) to Mic(-)            | Differential MIC                                                        |     | -10  |      | dBm0              |
| Differential Input Resistance – Mic(+) to Mic(-) | Differential MIC, MICAMP gain = 25.6 dB                                 |     | 36   |      | kΩ                |
| Microphone Pre-Amplifier Gain                    | Differential MIC                                                        |     | 25.6 |      | dB                |

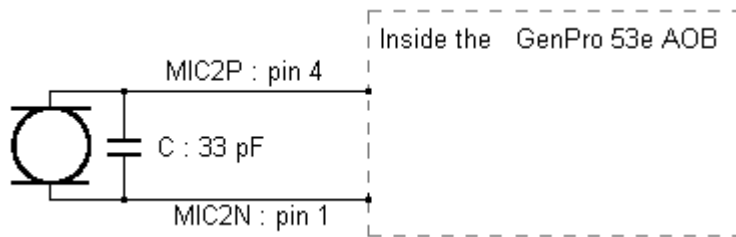

8.2.2.2 Loudspeaker

Output characteristics for the loudspeaker

| Loudspeaker output                   | Parameters/Conditions            | Min | Typ | Max | Units |
|--------------------------------------|----------------------------------|-----|-----|-----|-------|
| Maximum Differential Resistive Load  | Output Swing 3.9 V <sub>PP</sub> |     | 120 |     | Ω     |
|                                      | Output Swing 1.5 V <sub>PP</sub> |     | 33  |     | Ω     |
| Maximum Differential Capacitive Load |                                  |     |     | 100 | pF    |
| Common Mode Minimum Resistive Load   | At Internal Speaker (+) or (-)   |     | 200 |     | kΩ    |
| Common Mode Maximum Capacitive Load  | At Internal Speaker (+) or (-)   |     |     | 50  | pF    |
| Amplifier Gain                       | EARG = 1                         |     | 1   |     | dB    |
|                                      | EARG = 0                         |     | -11 |     | dB    |

| Parameters                                | Test Conditions                                                           | Min  | Typ    | Max | Units            |
|-------------------------------------------|---------------------------------------------------------------------------|------|--------|-----|------------------|
| Earphone output swing at EARP-EARN        | Distortion ≤ 2% and 120 Ω, VSP input level = +3 dBm0, amp gain = -11 dB   |      | 0.98   |     | V <sub>P-P</sub> |
|                                           | Distortion ≤ 2% and 33 Ω, VSP input level = -5.34 dBm0, amp gain = -11 dB |      | 0.38   |     | V <sub>P-P</sub> |
|                                           | Distortion ≤ 2% and 120 Ω, I2S input level = +3 dBm0, amp gain = -11 dB   |      | 0.93   |     | V <sub>P-P</sub> |
|                                           | Distortion ≤ 2% and 120 Ω, VSP input level = +3 dBm0, amp gain = -1 dB    | 3.1  | 3.92   |     | V <sub>P-P</sub> |
|                                           | Distortion ≤ 2% and 33 Ω, VSP input level = -5.34 dBm0, amp gain = -1 dB  | 1.2  | 1.5    |     | V <sub>P-P</sub> |
|                                           | Distortion ≤ 2% and 120 Ω, I2S input level = +3 dBm0, amp gain = -1 dB    | 2.96 | 3.7    |     | V <sub>P-P</sub> |
| Amplifier Gain                            | EARG = 1                                                                  |      | 1      |     | dB               |
|                                           | EARG = 0                                                                  |      | -11    |     | dB               |
| Earphone amplifier state in power down    |                                                                           |      | High Z |     |                  |
| Earphone amplifier power supply rejection | 1 kHz, 100 mVp-p                                                          |      | 50     |     | dB               |

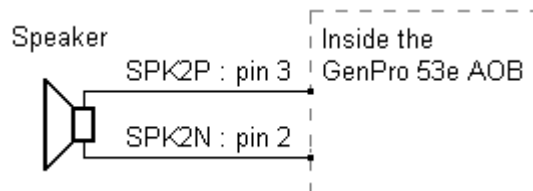

An external amplifier is necessary for a charge < 16 Ω or if the volume is not adapted.

8.2.2.3 Buzzer

Output characteristics

| Characteristics                      | Symbols     | Conditions                                                       | Min. | Typ. | Max. | Unit          |
|--------------------------------------|-------------|------------------------------------------------------------------|------|------|------|---------------|
| collector-base voltage               | $V_{CB0}$   | Transmitter open                                                 |      |      | 48   | V             |
| collector-emitter voltage            | $V_{CE0}$   | Open base                                                        |      |      | 40   | V             |
| collector current (DC)               | $I_C$       |                                                                  |      |      | 600  | mA            |
| peak collector current               | $I_{CM}$    |                                                                  |      |      | 800  | mA            |
| Collector Cutoff Current             | $I_{CB0}$   | $I_E = 0; V_{CB} = 60\text{ V}; T_j = 25\text{ }^\circ\text{C}$  |      |      | 10   | nA            |
|                                      |             | $I_E = 0; V_{CB} = 60\text{ V}; T_j = 125\text{ }^\circ\text{C}$ |      |      | 10   | $\mu\text{A}$ |
| collector-emitter saturation voltage | $V_{CEsat}$ | $I_C = 150\text{ mA}; I_B = 15\text{ mA}^*$                      |      |      | 300  | mV            |
|                                      |             | $I_C = 500\text{ mA}; I_B = 50\text{ mA}^*$                      |      |      | 1    | V             |
| transition frequency                 | $f_T$       | $I_C = 20\text{ mA}; V_{CE} = 20\text{ V}; f = 100\text{ MHz}$   |      |      | 300  | MHz           |
| collector capacitance                | $C_C$       | $I_E = I_e = 0; V_{CB} = 10\text{ V}; f = 1\text{ MHz}$          |      |      | 8    | pF            |
| total power dissipation              | $P_{Tot}$   | $T_{amb} \leq 25\text{ }^\circ\text{C}$                          |      |      | 225  | mW            |

Example of transducer tested with the [GenPro 53e](#) :

| Buzzer characteristics | Values                 |
|------------------------|------------------------|
| Type                   | Transducer AT-2720-T-R |
| Consumptions           | 1-30V peak/3.5mA max.  |
| Resonance frequency    | 2.048Hz $\pm$ 500HZ    |
| Acoustic level (SPL)   | Min.88dBA @10cm        |

The output assembly of the internal module is in open collector.

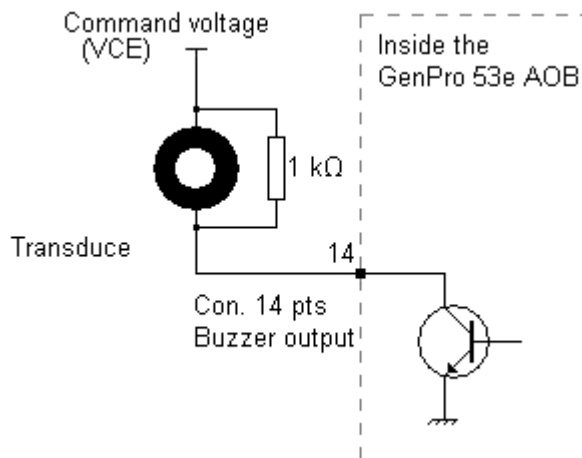

### 8.2.3 Inputs/Output

By default, the GenPro 53e provides

5 opto-coupled inputs (E1 to E5)

3 open collector outputs (S1 to S3).

2 analog inputs (ANA1, ANA2).

#### 8.2.3.1 Opto-coupled inputs

Table: Characteristics of opto-coupled inputs

| Characteristics              | Symbols             | Conditions                                   | Min. | Typ. | Max. | Unit          |
|------------------------------|---------------------|----------------------------------------------|------|------|------|---------------|
| Max. current                 | $I_{F (rms)}$       |                                              |      |      | 50   | mA            |
| Max.inverted tension         | $V_R$               |                                              |      |      | 5    | V             |
| Direct tension               | $V_F$               | $I_F = 10 \text{ mA}$                        | 1.0  | 1.15 | 1.3  | V             |
| Inverted current             | $I_R$               | $V_R = 5 \text{ V}$                          |      |      | 10   | $\mu\text{A}$ |
| Capacity                     | $C_T$               | $V=0, f = 1 \text{ MHz}$                     | ---  | 30   | ---  | pF            |
| Transfer Ratio               | $I_C / I_F$         | $I_F = 5 \text{ mA}, V_{CE} = 5 \text{ V}$   | 50   | ---  | 600  | %             |
| Saturation of transfer ratio | $I_C / I_{F (SAT)}$ | $I_F = 1 \text{ mA}, V_{CE} = 0.4 \text{ V}$ |      | 60   |      | %             |



The minimum of voltage command for voltage detection is: **5 V**



The maximum voltage command is : **35 V**

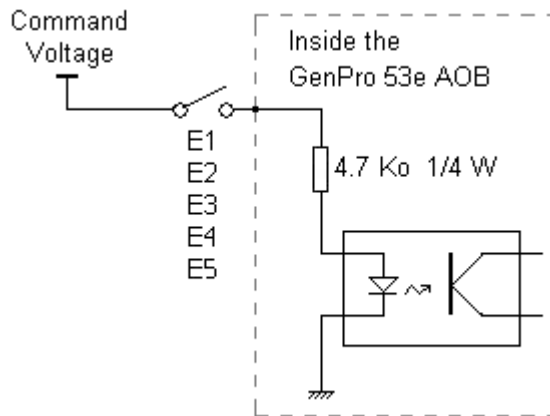

Internal electrical scheme of the three inputs

As an option (contact us) the inputs E3 and E5 can be insulated.

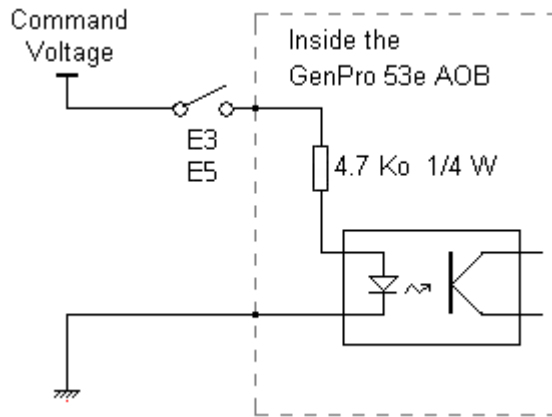

| Input        | E+   | E-   |
|--------------|------|------|
|              | pins | pins |
| E3 insulated | 11   | 10   |
| E5 insulated | 4    | 5    |

### 8.2.3.2 Output

Table: Characteristics of the open-collector output

| Characteristics    | Symbols     | Conditions                                     | Max. | Unit     |
|--------------------|-------------|------------------------------------------------|------|----------|
| max.Tension        | $V_{CE0}$   | Open transmitter                               | 48   | $V_{DC}$ |
| max.Tension        | $V_{CES}$   | $V_{BE} = 0 V$                                 | 48   | $V_{DC}$ |
| Collector current  | $I_C$       |                                                | 0.5  | A        |
| Saturation tension | $V_{CEsat}$ | $I_C = 500 mA$                                 | 1.3  | V        |
| Dissipation        | $P_{Tot}$   | $T_{amb} \leq 25 ^\circ C, T_j = 110 ^\circ C$ | 0.78 | W        |

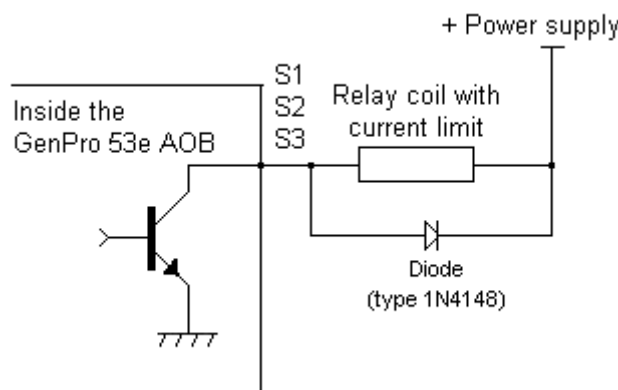

Electrical scheme of the output



No protection is provided. The user must respect the values of the table above..

8.2.3.3 Analog input

Table: Characteristics of the option analog input

| Characteristics      | Symbols  | Conditions             | Min.  | Typ. | Max.  | Unit             |
|----------------------|----------|------------------------|-------|------|-------|------------------|
| Analog input         | ANA1 / 2 |                        | -0.3  |      | 10.8  | V <sub>dc</sub>  |
| Conversion range     |          |                        | 1.3 μ |      | 10.33 | V <sub>dc</sub>  |
| Polarization current |          | From 1.3 μV to 10.33 V | 0.064 |      | 345   | μA <sub>dc</sub> |



The integrator has the responsibility to protect the input from electrical perturbations and to respect the values of the functioning parameters forecast.

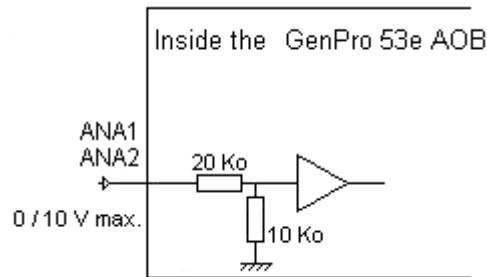

Internal electrical scheme of the option analog input

8.2.4 SIM interface

Table: Characteristics of the SIM card supply tension

|          |              |
|----------|--------------|
| SIM card | 3 V or 1.8 V |
|----------|--------------|

8.2.5 Option 2<sup>nd</sup> SIM interface

Contact us.

8.2.6 RESET signal

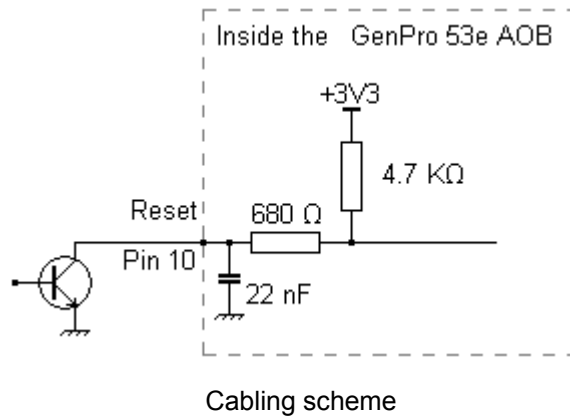

You must pass through a transistor assembly to use the RESET signal.

Table: Conditions of use

| Parameters      | Condition                 | Min. | Typ.  | Max. | Unit |
|-----------------|---------------------------|------|-------|------|------|
| V <sub>IL</sub> | Input Voltage – Low       | -0.3 |       | 0.8  | Vdc  |
| V <sub>IH</sub> | Input Voltage – High      | 2    |       | 3.3  | Vdc  |
| RIPU            | Internal Pull-Up Resistor |      | 5.38K |      | Ohms |

8.2.7 Characteristics of the RS232 serial links

The characteristics are the same for the 2 serial links RS\_232\_0 and RS232\_1

Table: Characteristics of the UART

| Characteristics       | Symbols            | Conditions            | Min. | Typ. | Max. | Unit |
|-----------------------|--------------------|-----------------------|------|------|------|------|
| Input Voltage – Range | V <sub>Input</sub> | Input Voltage – Range | -25  |      | +25  | Vdc  |
| Input Voltage – Low   | V <sub>IL</sub>    | Input Voltage – Low   | 0.6  | 1.1  |      | Vdc  |
| Input Voltage – High  | V <sub>IH</sub>    | Input Voltage – High  |      | 1.5  | 24   | Vdc  |
| Input Hysteresis      | V <sub>Hys</sub>   | Input Hysteresis      |      | 0.5  |      | Vdc  |
| Input Resistance      | R <sub>in</sub>    | Input Resistance      | 3    | 5    | 7    | KΩ   |

|                                     |                  |                                                    |     |      |     |    |
|-------------------------------------|------------------|----------------------------------------------------|-----|------|-----|----|
| Output Voltage                      | V <sub>out</sub> | All transmitter outputs loaded with 3 kΩ to ground | ±5  | ±5.4 |     | v  |
| Transmitter Output Resistance       | R <sub>out</sub> |                                                    | 300 | 50k  |     | Ω  |
| RS-232 Output Short-Circuit Current | I <sub>cc</sub>  |                                                    |     |      | ±60 | mA |



**8.2.8 RF GSM/DCS characteristics**

**8.2.8.1 RF functioning**

The RF functioning complies with the ETSI GSM Standards.

The RF performances for the receiver and the transmitter are described below.

Table: Parameters of the RF receiver and transmitter

|                                                                 |                                       |
|-----------------------------------------------------------------|---------------------------------------|
| Receiver                                                        |                                       |
| Sensitivity in 850/900                                          | - 106 dBm, GPRS Coding Scheme 1 (CS1) |
| Sensitivity in 1800/1900                                        | - 106 dBm, GPRS Coding Scheme 1 (CS1) |
| Transmitter                                                     |                                       |
| Maximum power (Power Class1 - 850/900) at ambient temperature   | 33 dBm +/- 2 dB @ antenna connection  |
| Maximum power (Power Class4 - 1800/1900) at ambient temperature | 30 dBm +/- 2 dB @ antenna connection  |

**8.2.8.2 GSM external antenna**

The GSM external antenna is connected to the modem via the FAKRA-D connector.

The external antenna must have the characteristics described in the table below.

Table: Characteristics of the GSM external antenna

|                      |                           |
|----------------------|---------------------------|
| Frequency band       | 850/900/1800/1900 MHz     |
| Impedance            | 50 Ohms nominal           |
| DC impedance         | 0 Ohm                     |
| Gain                 | 0 dBi in a mini direction |
| VSWR (Rx max TX max) | 1.5:1                     |
| Polarization         | Linear                    |



See paragraph 10 Recommended accessories, for the GSM antennas recommended by ERCO & GENER.

### 8.2.9 Power supply 3.8 V

When the battery is present, see the table below for the available tension.

Table: Conditions of use

| Parameters | Condition                    | Min. | Typ. | Max. | Unit |
|------------|------------------------------|------|------|------|------|
| Vout       | Without power supply *       | 2.8  |      | 4.2  | Vdc  |
|            | With power supply 5.5V - 32V | 4.4  |      | 4.5  | Vdc  |
| Iout       | Max.                         |      |      | 100  | mA   |

\* The GenPro 53e works only with battery.



The min. 2.8 V auto-protection limit of the battery. From this moment, the battery puts itself under protection, and the output tension becomes null.  
When the battery is not connected, the output tension is  $4.4V \leq V_{out} \leq 4.5 V$  as long as the power supply +VDC is present

### 8.2.10 Power\_Out power supply

Contact us.

### 8.2.11 Option 100V power supply

Contact us.

## 8.3 Environmental characteristics

To ensure a correct functioning of the modem, the limits listed in the table below must be respected.

Table: Environmental characteristics

|                                         |                  |
|-----------------------------------------|------------------|
| Operating temperature                   | -20 °C to +60 °C |
| Storage temperature                     | -40 °C to +85 °C |
| Operating humidity without condensation | HR < 70% @ +55°C |
| Atmospheric pressure                    | normal           |



When the temperature is more than 45 °C inside the box, the protection of the battery management triggers. The battery will not be charged.

## 8.4 Standards/Conformities

The product complies with the following requirements:

- R&TTE 1999/5/EC Directive,
- Regulations of standard ETSI EN 301 489-7 (02),
- ROHS Compliant : Directive 2002/95/CE,
- 2002/96/CE DEEE (crossed out wheelie bin).

The following marking appears under the device.



## 9 Security recommendations

### 9.1 General security

It is important to respect the specific regulations concerning the use of radio equipment, in particular with the possible risks of interference due to radio frequency (RF). Please respect carefully the following security advices.

Turn off your GSM modem:

- On an aircraft, the use of cellular telephone can endanger the plane operations; disturbing the cellular network is illegal. The non-observance of this instruction can lead to the suspension or the exclusion of the cellular phone services, or even to a trial, or both,
- At a refueling station,
- In any area with a potential explosive atmosphere that could cause an explosion or a fire,
- In hospitals and other places where medical equipment may be used.

Restrictions of use of radio equipments in:

- Fuel warehouses,
- Chemical factories,
- Places where destruction operations are in the running,
- Other places where signs indicate that the use of cellular phones is prohibited or dangerous.
- Other places where you should normally turn off the engine of your vehicle.

There can be a danger associated with the use of your GSM modem close to insufficiently protected medical devices such as acoustic devices and pacemakers.

Consult the manufacturers of medical equipment to know if it is adequately protected.

Using your GSM modem close to other electronic equipments may also cause interferences if the equipment is insufficiently protected.

Pay attention to the warnings and the recommendations of the manufacturers.

The modem is designed to be used with "fixed" and "mobile" applications:

- "Fixed" application: The GSM modem is physically linked to a site and it is not possible to move it easily to another site.
- "Mobile" application: The GSM modem is designed to be used in various places (other than fixed) and is intended to be used in portable applications.
- The modem must be used at more than 20cm from the human body.

This equipment is supplied in Very Low Security Voltage and at non-dangerous energy level.

## 9.2 Security in a vehicle

Do not use your Modem whilst driving, unless equipped with a correctly installed ear-piece/hands-free kit. Respect the national regulations concerning the use of cellular telephones in vehicles. Road safety is always a priority.

An incorrect installation of the GSM modem in a vehicle could cause an incorrect functioning of the vehicle's electronics. To avoid such problems, ensure that the installation was made by a qualified person. During the installation, a verification of the electronic protection system of the vehicle must be done.

The use of a warning equipment that activates the headlights or the horn of a vehicle on public highway is not authorized.

## 9.3 Care and maintenance

The suggestions hereunder will help you to preserve this product for many years.

Do not expose the modem to the extreme environments, to high temperature or high humidity.

Do not use or store the modem in dusty or dirty places, it could be damaged.

Do not try to disassemble the modem, at the risk of cancelation of the guarantee.

Do not expose the modem to water, rain or spilled beverage, it is not impermeable.

Avoid dropping, striking, or shaking the modem violently. The lack of care can damage it.

Do not place the modem next to computer disks, credit or travel cards or other magnetic supports. The information contained on disks or cards can be affected by the modem.

The use of other equipments or accessories not made or not authorized by ERCO & GENER can cancel the guarantee of the modem.



**The battery is not under guarantee.**

## 9.4 Your responsibility

This modem is under your responsibility. Treat it with care, it is not a toy. Keep it always in a secure place and out of the reach of children.

Try to remember your PIN and PUK codes. Familiarize yourself with the modem and use the security functions to lock it in case of non authorized using or in case of theft.

## 10 Recommended Accessories

The accessories recommended by ERCO & GENER for the modem [GenPro 53e](#), are described on our website in the section Products/Accessories. For more information, contact our sales department.

## 11 Client support

ERCO & GENER ensures the client support for all its modems sold. You will then have access to:

- The latest version of this document
- The datasheet of the product
- The latest versions of the OS user guides
- Certificates
- Application notes



---

The support concerning the EGM developments is optional (contact us).

---

