



FEATURE HIGHLIGHTS

- Access data through Modbus/TCP/RTU/ASCII
- Supports MQTT for IIoT applications
- 2 x redundant LAN ports
- Support for MQTT Security over TLS
- Optional WiFi version with Client mode
- Up to 20 x different I/O combinations available
- Industrial EMC protection
- Wide operating temperature range: -40°C~70°C*

PRODUCT DESCRIPTION

As an IIoT I/O module, ATOP's IO5202 Series is a compact solution for connecting digital and analog devices and sensors, enabling you to monitor, acquire and process data from remote sensors and control digital and analog outputs. The IO5202 Series is a cost-effective solution for integrating existing applications into an IIoT framework, such as automated manufacturing, building management and control, and agricultural and irrigation systems.

For applications in which running cable can be impractical, then the IO5202 WiFi-equipped version is a cable-free solution for widely disappeared devices and sensors, which also allows for better scalability for operations that continue to evolve and grow.

Offering plug-and-play simplicity, the IO5202 Series supports numerous protocols, including Modbus TCP/RTU/ASCII, MQTT, MQTT over TLS and SNMP. Using the intelligent processing and publishing features of the IO5202 Series, data can be polled, logged, or even automatically pushed when I/O statuses change.

Supporting numerous configurations options to support various types of digital I/O, analog I/O, and relay scenarios, the IO5202 Series has been designed for demanding industrial applications that require compact solutions while delivering high network performance. Supporting a wide operating temperature range of -40°C~70°C* and Industrial EMC protection, the IO5202 Series can perform under a variety of environmental conditions, such as power input voltage, shock, drop and vibration.

* non-wireless models only

APPLICATION

In situations where running cable is impractical, IO5202 WiFi-equipped version comes handy as a cable-free solution for widely disappeared devices and sensors. It also allows for better scalability for operations that continue to evolve and grow.

The IO5202 Series supports **Modbus TCP/RTU/ASCII, MQTT, MQTT over TLS and SNMP**. Using the intelligent processing and publishing features, data can be polled, logged, or even automatically pushed when I/O statuses change. **Also, data can be pushed to connect and interact with a public or private cloud servers.**

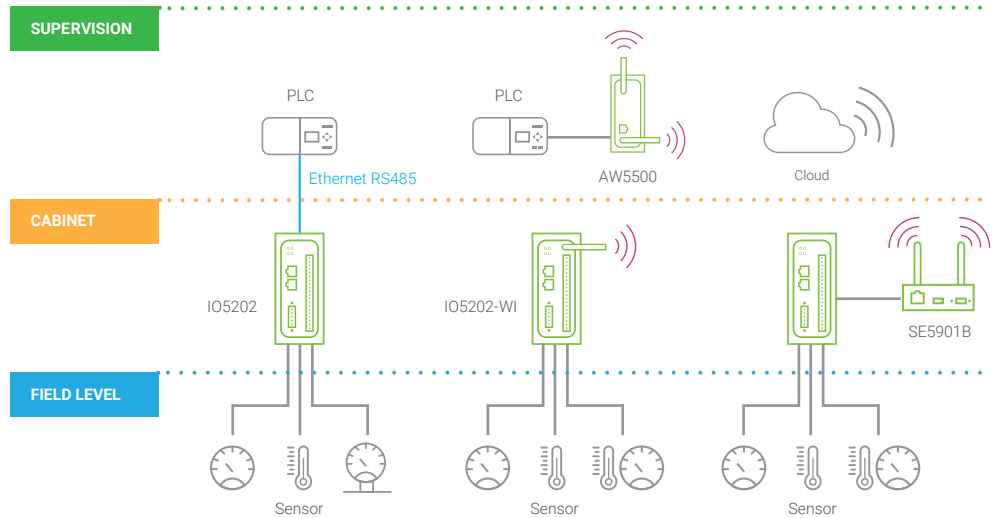

AVAILABLE COMBINATION

Model Name	Serial port	Digital I/Os	Relay Outputs	Analog Inputs	Analog Outputs	Wi-Fi	Remark
IO5202-DB-16-0-0-0	DB9	16	0	0	0	No	8 DI/ 8 DO
IO5202-TB-16-0-0-0	TB5	16	0	0	0	No	8 DI/ 8 DO
IO5202-DB-0-0-8-0	DB9	0	0	8	0	No	
IO5202-TB-0-0-8-0	TB5	0	0	8	0	No	
IO5202-DB-6-2-4-0	DB9	6	2	4	0	No	
IO5202-TB-6-2-4-0	TB5	6	2	4	0	No	
IO5202-DB-8-4-0-0	DB9	8	4	0	0	No	8 DIO, Jumper Selectable
IO5202-TB-8-4-0-0	TB5	8	4	0	0	No	8 DIO, Jumper Selectable
IO5202-DB-0-0-4-4	DB9	0	0	4	4	No	
IO5202-TB-0-0-4-4	TB5	0	0	4	4	No	
IO5202-DB-16-0-0-0-W	DB9	16	0	0	0	Yes	8 DI/ 8 DO
IO5202-TB-16-0-0-0-W	TB5	16	0	0	0	Yes	8 DI/ 8 DO
IO5202-DB-0-0-8-0-W	DB9	0	0	8	0	Yes	
IO5202-TB-0-0-8-0-W	TB5	0	0	8	0	Yes	
IO5202-DB-6-2-4-0-W	DB9	6	2	4	0	Yes	
IO5202-TB-6-2-4-0-W	TB5	6	2	4	0	Yes	
IO5202-DB-8-4-0-0-W	DB9	8	4	0	0	Yes	8 DIO, Jumper Selectable
IO5202-TB-8-4-0-0-W	TB5	8	4	0	0	Yes	8 DIO, Jumper Selectable
IO5202-DB-0-0-4-4-W	DB9	0	0	4	4	Yes	
IO5202-TB-0-0-4-4-W	TB5	0	0	4	4	Yes	

SPECIFICATIONS

Technical Specifications	
Model Name	I05202
Ethernet	
Compliance	IEEE802.3 for 10BASE-T IEEE802.3u for 100BASE-T(X)
Number of ports Transmission Rate Auto MDI/MDI-X	2x RJ45 10/100 Mbps Yes
Serial	
Mode	RS-232/ RS-422 / RS-485 (2-wire and 4-wire)
Number of ports	1x
Connector	5-pin 3.81mm Terminal Block (-TB models) or 9-pin D-Sub9 (-DB models)
Baud rate	1200~234,000 bps
Data bits	7,8 software selectable
Stop bits	1,2 software selectable
Auto-detection	RS-485 auto-detection by hardware
Wireless LAN (-W version only)	
Standard	802.11b (2.4GHz) 802.11g (2.4GHz) 802.11n (2.4GHz)
Antennas	1x RP-SMA(F) connector
Max. Throughput	72.2Mbps using 20MHz bandwidth - 150Mbps using 40MHz bandwidth
Frequencies	FCC/IC (US/CA): 2412~2462MHz; TSI(EU)/Japan: 2412~2472MHz
Encryption	WPA, WPA2, 802.1x, 802.11i, Open, Shared Key, Pair-wise-key authentication
Power	
Input Voltage	12-48VDC
Input Current	0.6~0.2A
Max. Power Consumption	9.6W
Reverse polarity protection	Present
Connector	5.08mm 3-Pin Lockable Terminal Block
LED	
Indicators	PWR, RUN, RJ45 Act/Link, COM1 Tx, COM1 Rx, Wireless
Software features	
Protocols	TCP, IPv4, UDP, DHCP Client/Server, HTTP, HTTPS, NTP client, Telnet, ARP, SNMPv1,v2c,v3, serial console(on-board connector), MQTT, MQTT Security over TLS, SMTP/ SMTP with TLS

Wireless Options (-W only)	Client mode
I/O access	Modbus TCP/RTU/ASCII, MQTT publisher/subscriber
Other I/O software features	Mirror function
Physical Characteristics	
Housing	IP30 protection according to EN 60529
Material	SPCC
Dimension (W x H x D)	45.3 x 89.6 x 110 mm
Weight	350g
Installation	DIN-rail or wall-mount (optional)
Environmental Limits	
Operating Temperature	-40~70°C (-40~158°F) - 0~65°C (34~149°F) Wireless version only
Storage Temperature	-40~85°C (-40~185°F) - -20~85C (-4~185F) Wireless version only
Ambient Relative Humidity	5~95% RH (non-condensing)

I/O Specifications	
Digital Inputs	
Input Type	Single status (wet or dry contact) or counter
Dry contact	Logic 1: short to GND, Logic 0: open
Wet contact	Logic 1: 0 to 3 VDC, Logic 0: 10 to 30 VDC
Counter Frequency	250 Hz
Isolation	3K Vrms
Digital Outputs	
Output Type	Output or Pulse output
Nominal Voltage	30 VDC
Current Rating	max 500 mA totally
Over-voltage Protection	45 VDC
Over-current Protection	2.6A
Over-temperature shutdown	175°C
Isolation	3K Vrms
Relay Outputs	
Form	Form A power relay
Isolation resistance	1G Ω @500VDC
Isolation between contacts	3K Vrms
Analog Inputs	
Current contact rating	Voltage/Current Software Selectable
Input Range	Voltage: ±60m VDC, ±500m VDC, ±1 VDC, ±5 VDC, ±10 VDC Current: 4 to 20 mA
Resolution	16 bits

Accuracy	$\pm 0.1\%$ FSR (Voltage)@ 25 °C $\pm 0.2\%$ FSR (Current)@ 25 °C
Sampling Rate	> 10 samples/sec (per channel)
Isolation	3K VDC or 2K Vrms
Analog Outputs	
Output Type	Voltage/Current Software Selectable
Voltage Range	Voltage: ± 10 VDC
Current Range	Current: 4 to 20 mA
Resolution	16 bits
Accuracy	$\pm 0.1\%$ FSR @ 25 °C
Load Resistor	Internal resistor, 500 Ω

DIMENSIONS & LAYOUT

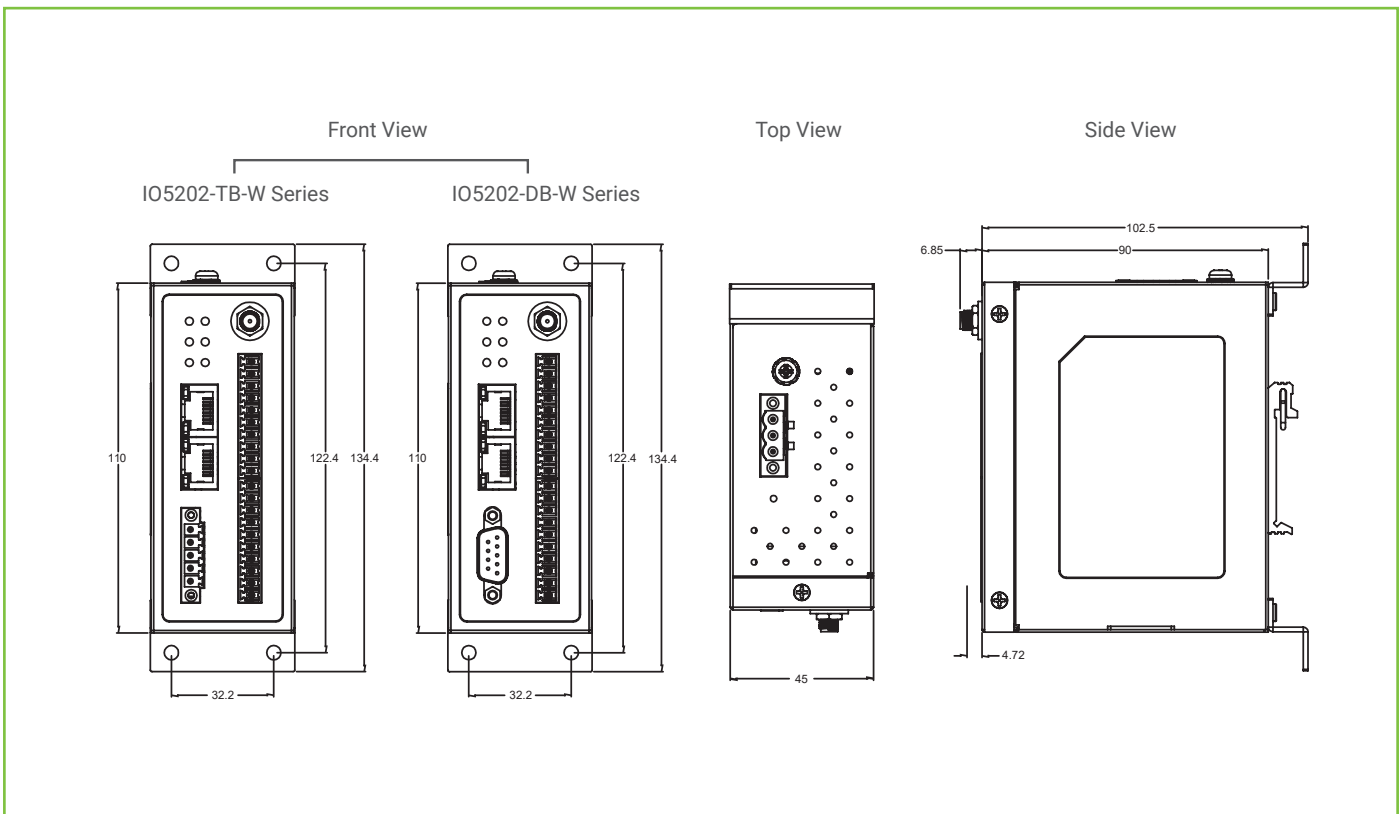

REGULATORY APPROVALS

Regulatory Approvals					
Safety	EN62368-1				
EMC	EN55032:2015+AC:2016, EN61000-6-4:2007+A1:2011, EN55024:2010+A1:2015, EN61000-6-2:2005+AC:2005, EN301489-1 v2.2.0 / EN301489-17 v3.2.0 FCC Part 15B FCC Part 18				
Radio	FCC Part 15.247 for WIFI b/g/n EN300328 V2.1.1 for WIFI b/g/n				
Test	Version	Item		Value	Level
IEC 61000-4-2	2009	ESD	Contact Discharge	±4KV	2
			Air Discharge	±8KV	3
IEC 61000-4-3	2010	RS	80-1000MHz	10(V/m)	3
			1.4-6.0GHz	3(V/m)	2
IEC 61000-4-4	2012	EFT	DC Power Port	±1.0KV	2
			Signal Port	±1.0KV	3
IEC 61000-4-5	2017	Surge	DC Power Port	Line-to Line± 0.5 KV	2
			DC Power Port	Line-to Earth± 1 KV	2
			Signal Port	Line-to Earth± 1 KV	2
IEC 61000-4-6	2013	CS	DC Power Port	10 V rms	3
IEC 61000-4-8	2009	PfMF	Enclosure	30A/m	4
Shock	MIL-STD-810F Method 516.5				
Drop	MIL-STD-810F Method 516.5				
Vibration	MIL-STD-810F Method 514.5 C-1 & C-2				
RoHS	Yes				
MTBF	22.66 Years				
Warranty	5 Years				

ORDERING INFORMATION

Ordering Information

Model name	Part Number	Description
IO5202-DB-16-0-0-0	1P1IO520200001G	1x RS232/422/485 DB9,2x 10/100Mbps,8 DOs,8 DIs
IO5202-TB-16-0-0-0	1P1IO520200002G	1x RS232/422/485 TB5,2x 10/100Mbps,8 DOs,8 DIs
IO5202-DB-0-0-8-0	1P1IO520200003G	1x RS232/422/485 DB9,2x 10/100Mbps,8 AIs
IO5202-TB-0-0-8-0	1P1IO520200004G	1x RS232/422/485 TB5,2x 10/100Mbps,8 AIs
IO5202-DB-6-2-4-0	1P1IO520200005G	1x RS232/422/485 DB9, 2x 10/100Mbps, 6DIs, 4 AIs, 2 Rlys
IO5202-TB-6-2-4-0	1P1IO520200006G	1x RS232/422/485 TB5, 2x 10/100Mbps, 6DIs, 4 AIs, 2 Rlys
IO5202-DB-8-4-0-0	1P1IO520200007G	1x RS232/422/485 DB9,2x 10/100Mbps,8DIO, 4 Rlys
IO5202-TB-8-4-0-0	1P1IO520200008G	1x RS232/422/485 TB5,2x 10/100Mbps,8DIO, 4 Rlys
IO5202-DB-0-0-4-4	1P1IO520200009G	1x RS232/422/485 DB9,2x 10/100Mbps,4 AIs, 4 AOs
IO5202-TB-0-0-4-4	1P1IO52020000AG	1x RS232/422/485 TB5,2x 10/100Mbps,4 AIs, 4 AOs
IO5202-DB-16-0-0-0-W	1P1IO52020000BG	1x RS232/422/485 DB9,2x 10/100Mbps,8 DOs,8 DIs Wi-Fi
IO5202-TB-16-0-0-0-W	1P1IO52020000CG	1x RS232/422/485 TB5,2x 10/100Mbps,8 DOs,8 DIs Wi-Fi
IO5202-DB-0-0-8-0-W	1P1IO52020000DG	1x RS232/422/485 DB9,2x 10/100Mbps,8 AIs, WiFi
IO5202-TB-0-0-8-0-W	1P1IO52020000EG	1x RS232/422/485 TB5,2x 10/100Mbps,8 AIs,WiFi
IO5202-DB-6-2-4-0-W	1P1IO52020000FG	1x RS232/422/485 DB9, 2x 10/100Mbps, 6DIs, 4 AIs, 2 Rlys, Wi-Fi
IO5202-TB-6-2-4-0-W	1P1IO52020000GG	1x RS232/422/485 TB5, 2x 10/100Mbps, 6DIs, 4 AIs, 2 Rlys, Wi-Fi
IO5202-DB-8-4-0-0-W	1P1IO52020000HG	1x RS232/422/485 DB9,2x 10/100Mbps,8DIO,4 Rlys,WiFi
IO5202-TB-8-4-0-0-W	1P1IO52020000IG	1x RS232/422/485 TB5,2x 10/100Mbps,8DIO,4 Rlys,WiFi
IO5202-DB-0-0-4-4-W	1P1IO52020000JG	1x RS232/422/485 DB9,2x 10/100Mbps,4 AIs, 4 AOs,WiFi
IO5202-TB-0-0-4-4-W	1P1IO52020000KG	1x RS232/422/485 TB5,2x 10/100Mbps,4 AIs, 4 AOs,WiFi

Optional Accessories

Model name	Part Number	Description
SDR-75-24	50500752240001G	75W DIN-Rail 24VDC pwr supply,88~264VAC /124~370VDC input
UN315-1212(US-Y) LV6	50500151120003G	Y-Type (5.08 mm) power adaptor, 100-240VAC input, 1.25A @ 12VDC output, US plug, LV6.
UNE315-1212(EU-Y)LV6	50500151120013G	Y-Type (5.08 mm) adaptor, 100-240VAC input, 1.25A @ 12VDC output, EU plug
ADP-DB9(F)-TB5	59906231G	Female DB9 to Female 3.81mm TB5 Converter
WMK-454-Black	70100000000043G	Black Aluminum Wall Mount Kit